

VICOR CONFIDENTIAL
 THIS DOCUMENT AND THE DATA DISCLOSED HEREIN OR
 HEREIN IS NOT TO BE REPRODUCED, USED OR
 DISCLOSED IN ANY MANNER OR IN PART TO ANYONE WITHOUT
 THE PERMISSION OF VICOR CORP.

REV.	DESCRIPTION	INTL	DATE	APVD
1	RELEASED PER E140954g	SJW	10/30/14	RH

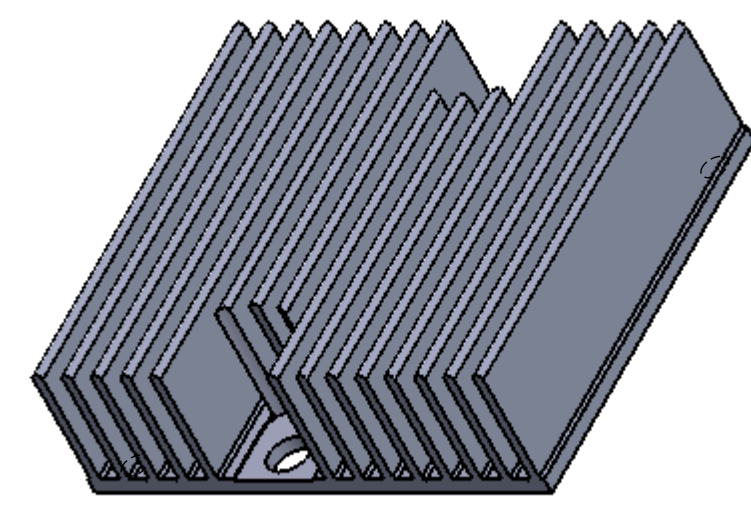
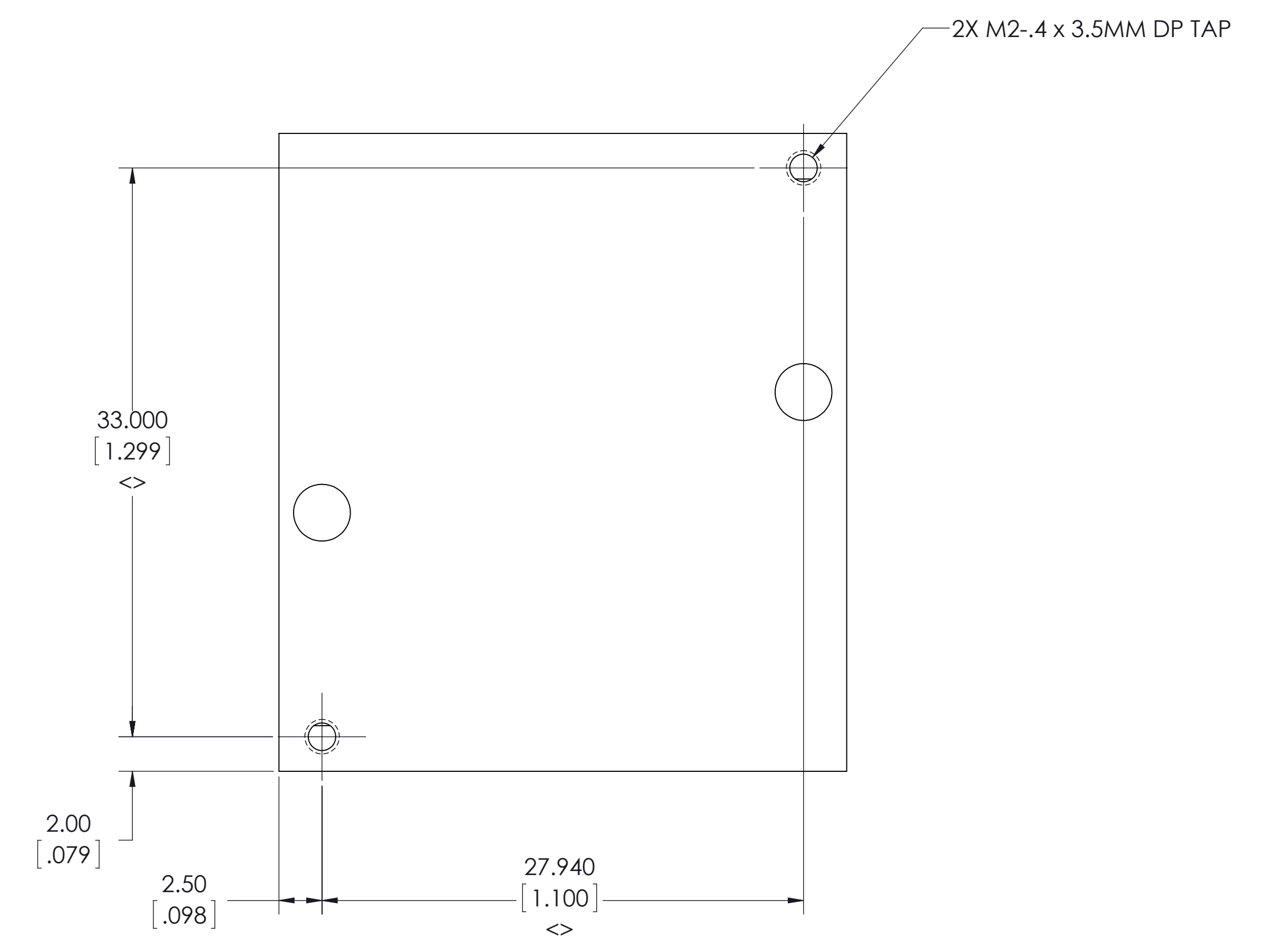
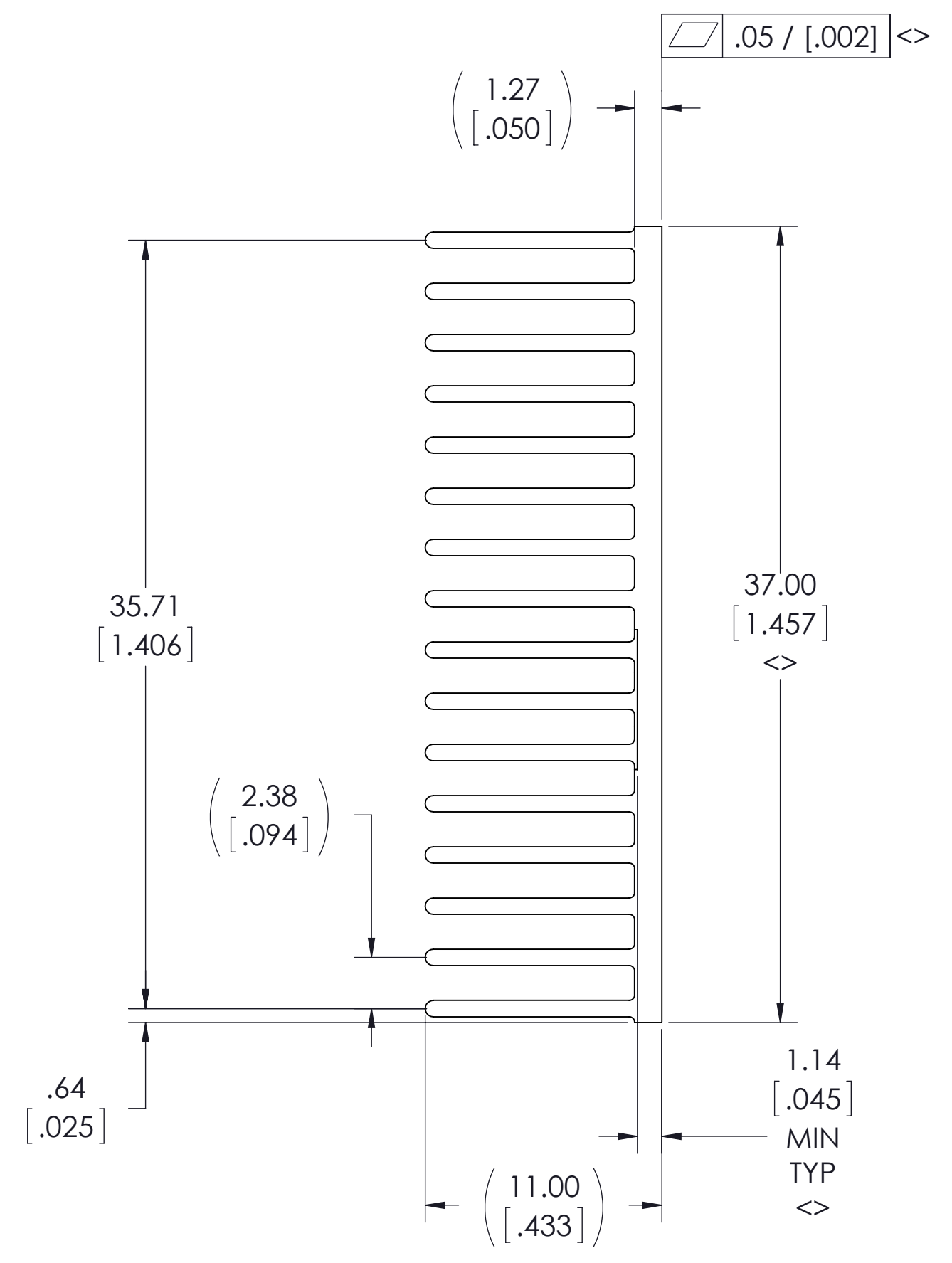
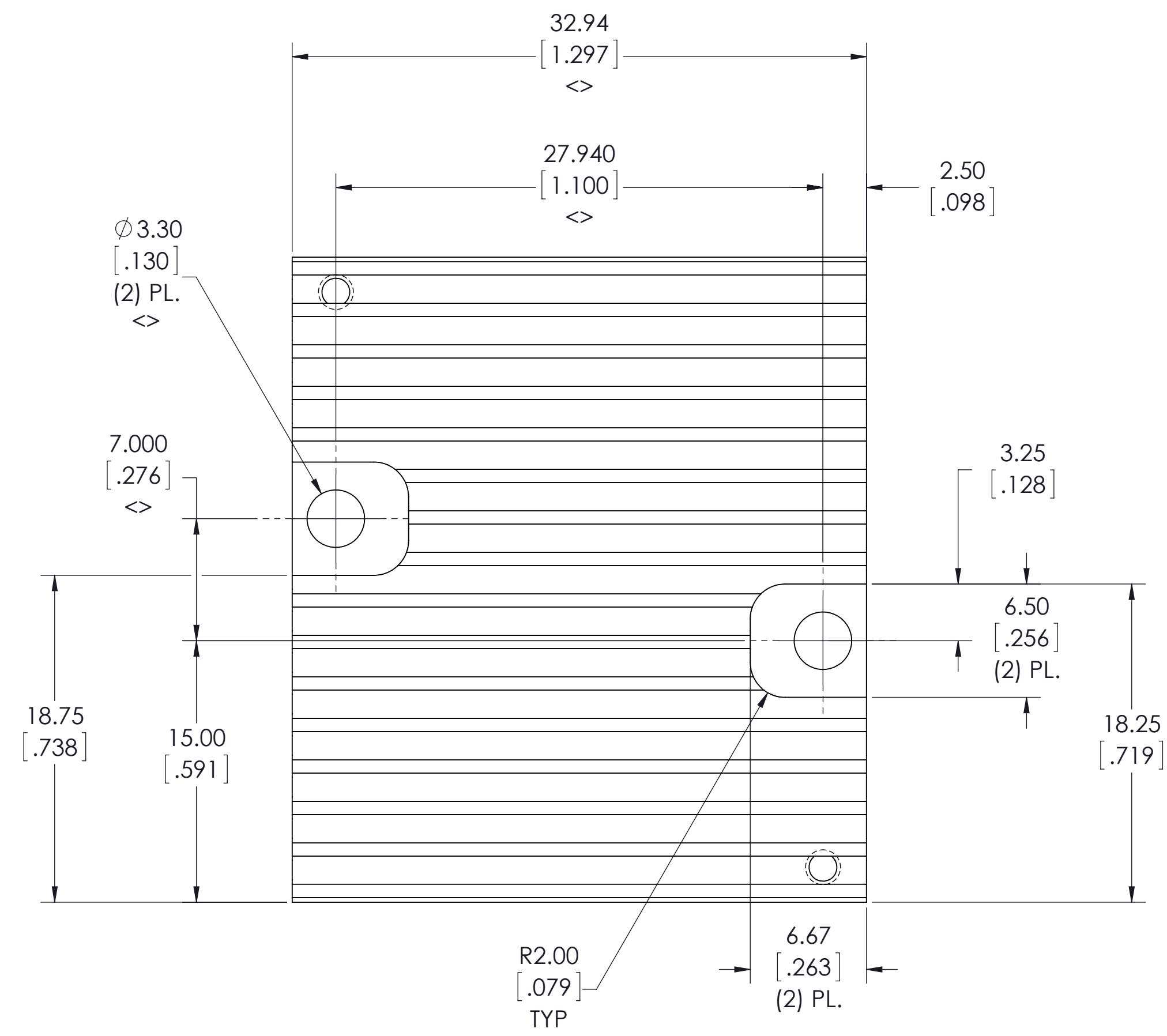
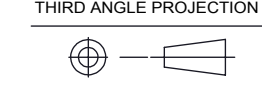

- NOTES:
- 1- MAKE FROM VICOR P/N 30827.
 - 2- FINISH: CLEAR FINISH, RoHS COMPLIANT PER CST-0001, LATEST REVISION PER
 A.) CHROMIUM FREE, OR
 B.) TRIVALENT CHROMIUM IN ACCORDANCE WITH MIL-DTL-5541, TYPE II, CLASS
 1A OR 3. SEE CST-0003 FOR TYPES OF AVAILABLE FINISHES.
 - 3- REMOVE ALL BURRS AND SHARP EDGES.
 - 4- $\langle \rangle$ DENOTES CRITICAL CHARACTERISTIC FOR LOT INSPECTION.
 - 5- ROHS COMPLIANT, LEAD FREE PER CST-0001 LATEST REVISION.

DRAWN BY Chris Stewart	DATE 04/04/2013	VICOR <small>swd</small>	
UNLESS OTHERWISE SPECIFIED DIMENSIONS ARE MM (INCH)		HEATSINK, PUSH PIN, XF, 3623, 11MM	
TOLERANCES ARE: DECIMALS ANGLES XXX (XX) = +0.25 (0.01) +1° XXXX (XXX) = ±0.127 (0.005)		SIZE D	CAGE CODE 67131
THIRD ANGLE PROJECTION  DO NOT SCALE DRAWING		DWG NO 39824	REV 1
SCALE 4:1		SHEET 1 OF 1	