

VICOR CONFIDENTIAL  
 THIS DOCUMENT AND THE DATA DISCLOSED HEREIN OR  
 HEREIN IS NOT TO BE REPRODUCED, USED OR  
 DISCLOSED IN WHOLE OR IN PART TO ANYONE WITHOUT  
 THE PERMISSION OF VICOR CORP.

REV.	DESCRIPTION	INTL	DATE	APVD
1	RELEASED PER E140954a	SJW	10/30/14	RH

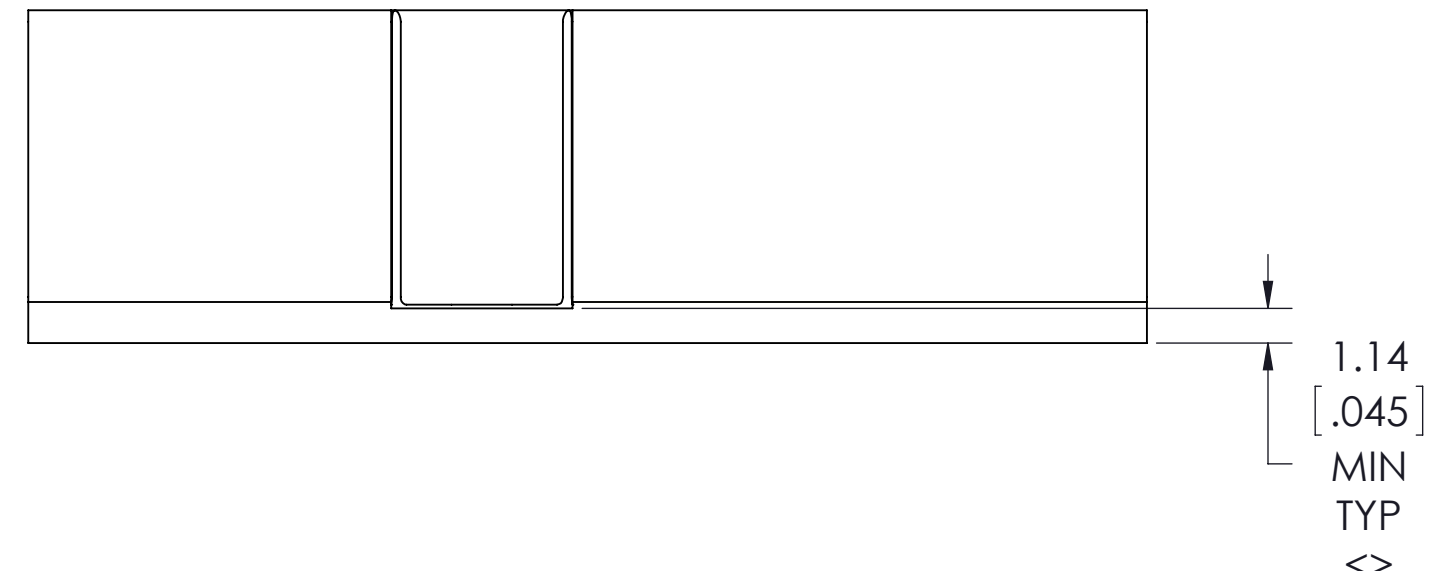

- NOTES:
- 1- MAKE FROM VICOR P/N 32618.
  - 2- FINISH: CLEAR FINISH, RoHS COMPLIANT PER CST-0001, LATEST REVISION PER  
 A.) CHROMIUM FREE, OR  
 B.) TRIVALENT CHROMIUM IN ACCORDANCE WITH MIL-DTL-5541, TYPE II, CLASS  
 1A OR 3. SEE CST-0003 FOR TYPES OF AVAILABLE FINISHES.
  - 3- REMOVE ALL BURRS AND SHARP EDGES.
  - 4- <> DENOTES CRITICAL CHARACTERISTIC FOR LOT INSPECTION.
  - 5- ROHS COMPLIANT, LEAD FREE PER CST-0001 LATEST REVISION.

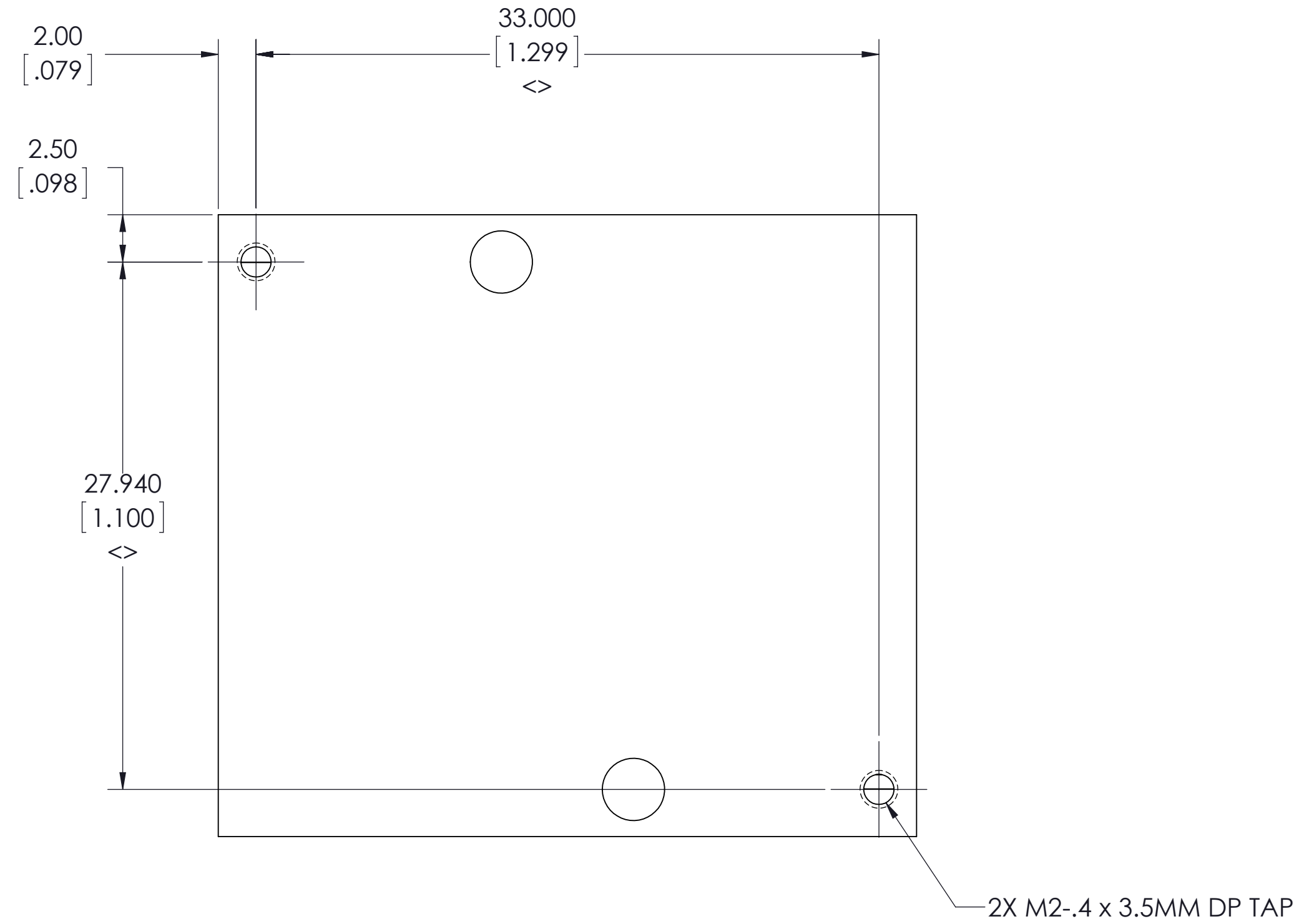
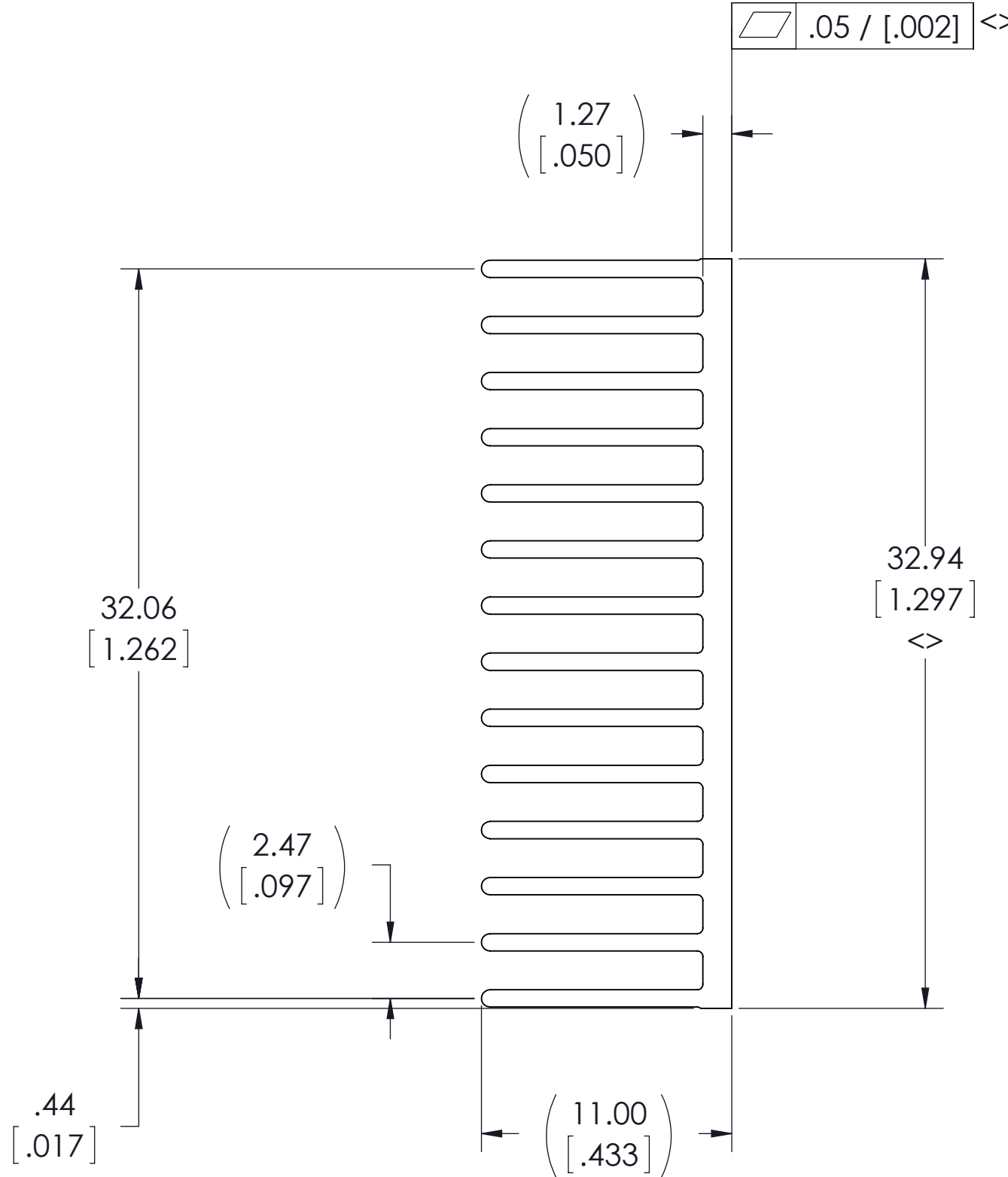
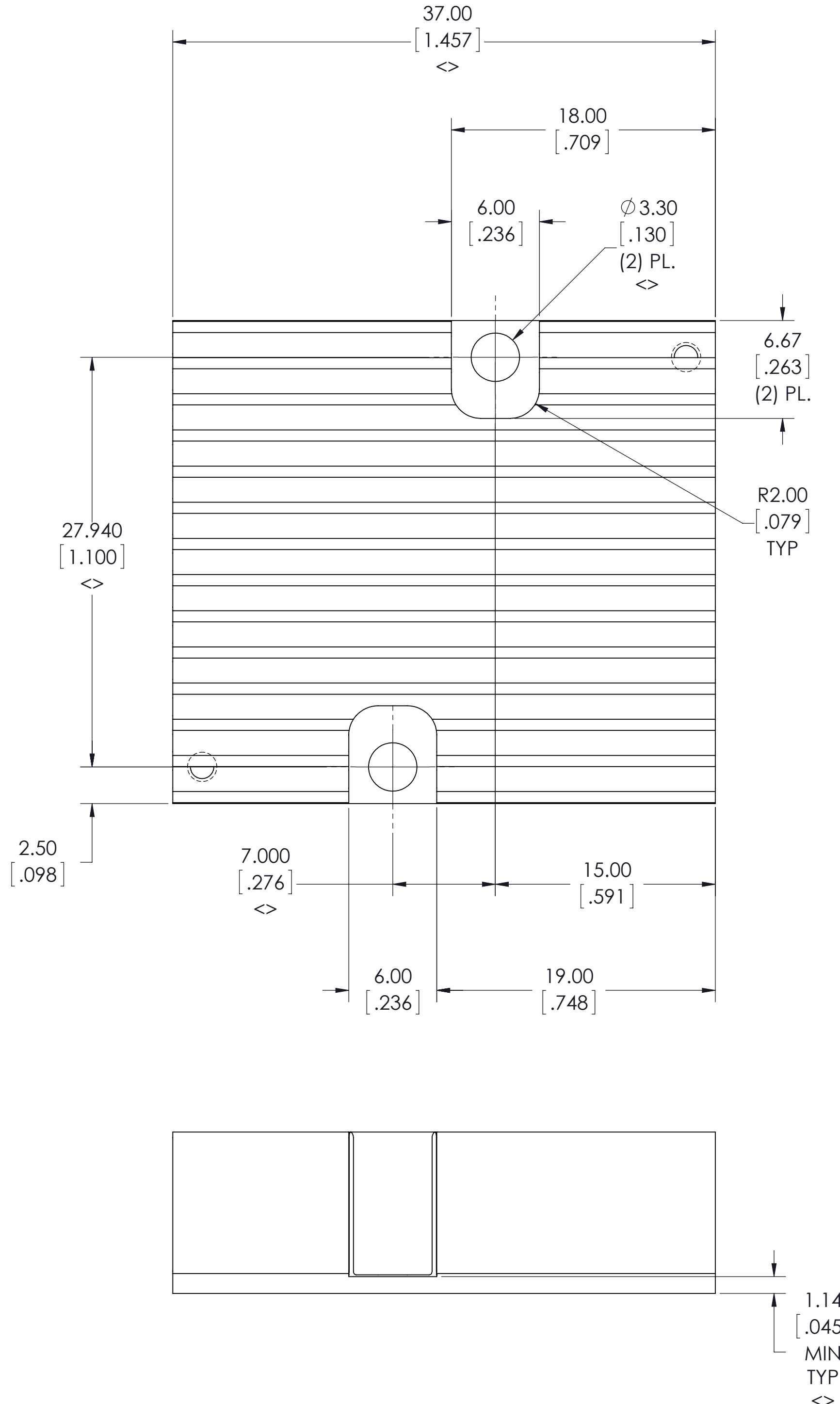
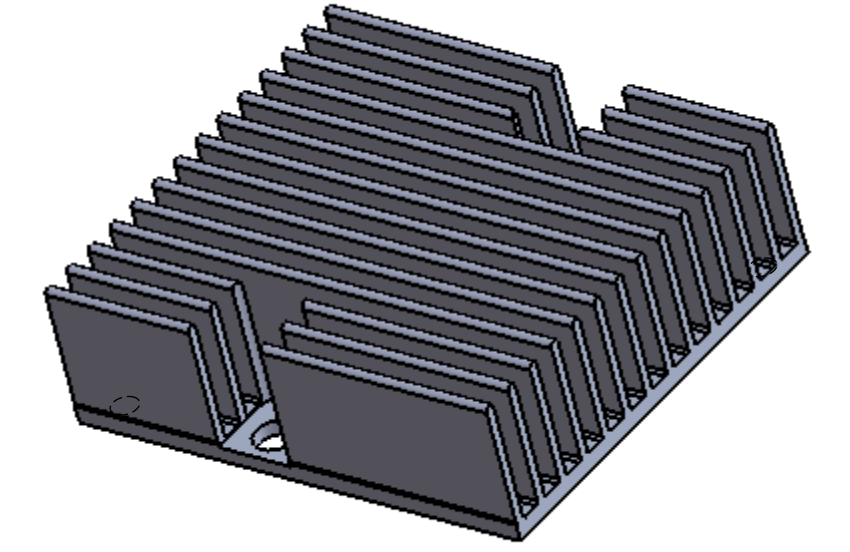

DRAWN BY Chris Stewart	DATE 04/04/2013	<b>VICOR</b> <small>swd</small>	
UNLESS OTHERWISE SPECIFIED DIMENSIONS ARE MM (INCH)		<b>HEATSINK, PUSH PIN, LF, 3623, 11MM</b>	
TOLERANCES ARE: DECIMALS ANGLES XXX (XX) = +0.25 (0.01) -1° X.XXX (X.XXX) = ±0.127 (0.005)		SIZE <b>D</b>	CAGE CODE <b>67131</b>
THIRD ANGLE PROJECTION 		DWG NO <b>39823</b>	REV <b>1</b>
DO NOT SCALE DRAWING		SCALE 4:1	SHEET 1 OF 1