

8

7

6

5

4

3

2

1

VICOR CONFIDENTIAL

THIS DOCUMENT AND THE DATA DISCLOSED HEREIN OR HEREWITH IS NOT TO BE REPRODUCED, USED OR DISCLOSED IN WHOLE OR IN PART TO ANYONE WITHOUT THE PERMISSION OF VICOR CORP.

REVISIONS

REV	DESCRIPTION	DATE	APPROVED
1	RELEASE PER E080414	02/27/08	AR
2	REVISED PER E100698A	5/19/10	JG
3	REVISED PER E100764	06/07/10	KUK

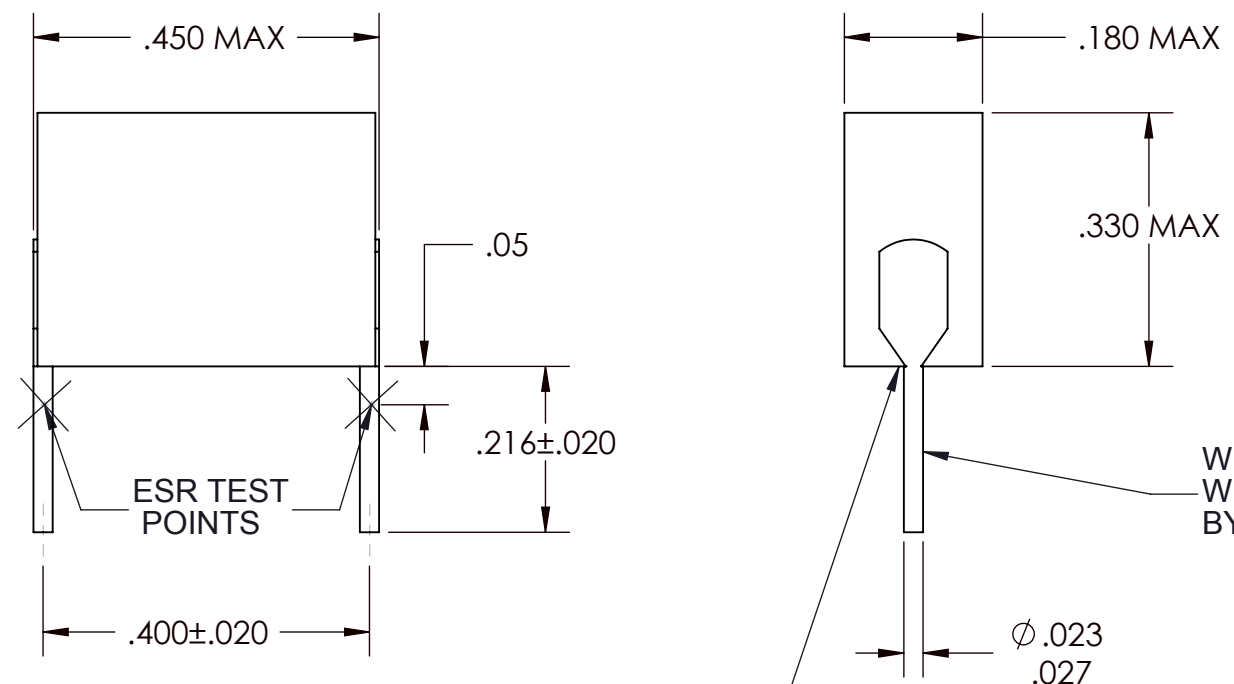

WIRE TO BE #22 AWG STEEL WIRE WITH 40 MICRO INCHES NICKEL FINISHED, FOLLOWED BY 100-300 MICRO INCHES OF MATTE TIN FINISH.

CAPACITOR SHALL SIT FLUSH ON PCB, UTILIZING 0.045 PCB HOLES

NOTES:

- LEADS TO BE LOCATED ON CENTER OF CAPACITOR BODY ±.015
- ACCEPTED MATERIAL & CONSTRUCTION:
A:) METALLIZED POLYESTER STACKED FILM.
- MECHANICAL LEAD INTEGRITY:
LEAD PULL=15.0 LBS. MIN.
LEAD PEEL=2.0 LBS. MIN.
- ROHS COMPLIANT, LEAD FREE PER CST-0001 LATEST REVISION.
- DIMENSIONS ARE INCHES ONLY.

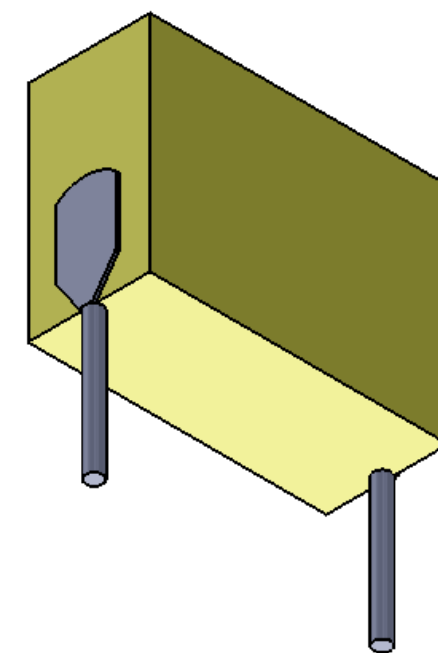

ELECTRICAL CHARACTERISTICS @ T=25°C (UNLESS OTHERWISE SPECIFIED)

PARAMETER	SYMBOL	MIN	TYP	MAX	UNITS	TEST CONDITIONS
CAPACITANCE	C	.5490	.61	.6710	uF	@ 1Vrms
CAPACITANCE	C	.49		.74	uF	@ 1KHz, -55°C TO +125°C, 0 TO 250 VOLTS
LEAKAGE CURRENT	I _{DCL}			0.10	uA	@V _{DCW}
EQUIVALENT SERIES RESISTANCE	ESR			60	mΩ	@ 100 KHz
WORKING VOLTAGE	V _{DCW}	250			V	
DISSIPATION FACTOR	D			0.8	%	@ 1.0KHz
OPERATING TEMPERATURE	T	-55°C +125°C			°C	
DIELECTRIC STRENGTH	V	325			V	2 SECONDS

DRAWN	DATE			SWD	
S ASHRAF	02/21/08				
MATERIAL	UNLESS OTHERWISE SPECIFIED DIMENSIONS ARE INCH [MM] TOLERANCES ARE: DECIMALS ANGLES X.XX [X.X] = ±0.01 [0.25] ±1° X.XXX [X.XX] = ±0.005 [0.127]		CAP FILM 0.61uF 10% 250V RDL		
FINISH	THIRD ANGLE PROJECTION	SIZE			CAGE CODE
		B	67131	34610	3
DO NOT SCALE DRAWING		SCALE 4 : 1		SHEET 1 OF 1	

8

7

6

5

4

3

2

1