

THIS DOCUMENT AND THE DATA DISCLOSED HEREIN OR HEREWITH IS NOT TO BE REPRODUCED, USED OR DISCLOSED IN WHOLE OR IN PART TO ANYONE WITHOUT THE PERMISSION OF VICOR CORP.

REVISIONS

REV	DESCRIPTION	DATE	APPROVED
1	RELEASED PER E054246	1/3/06	ECF
2	REVISED PER E100888A	7/9/10	DCS

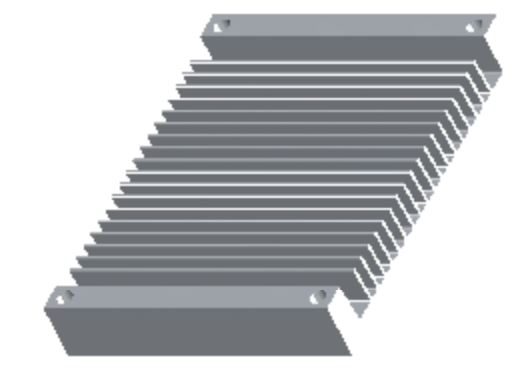
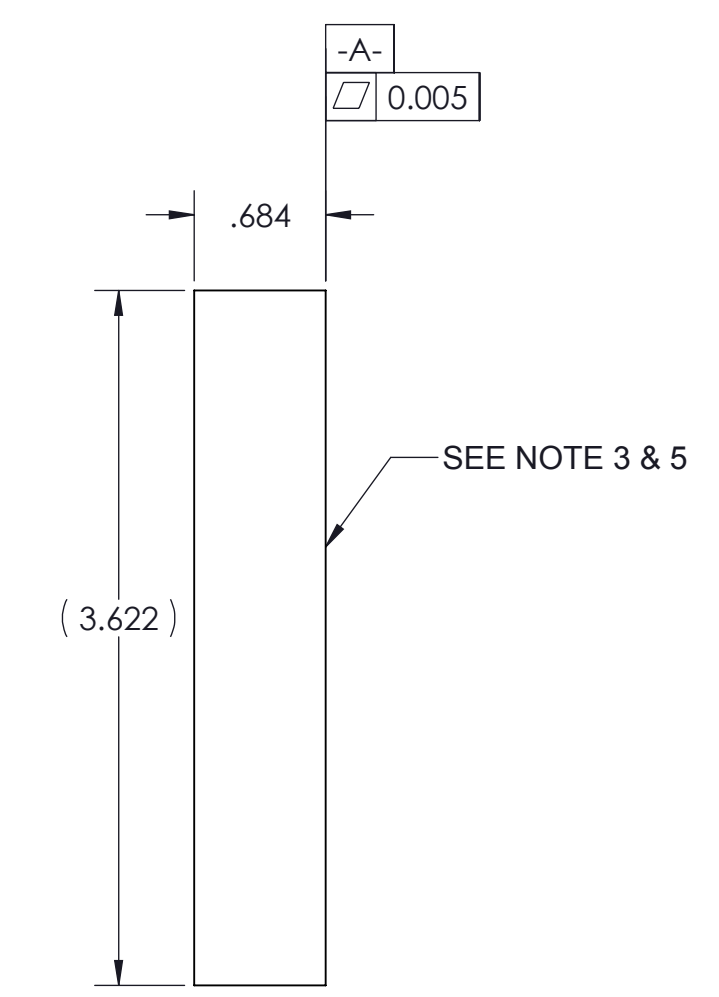
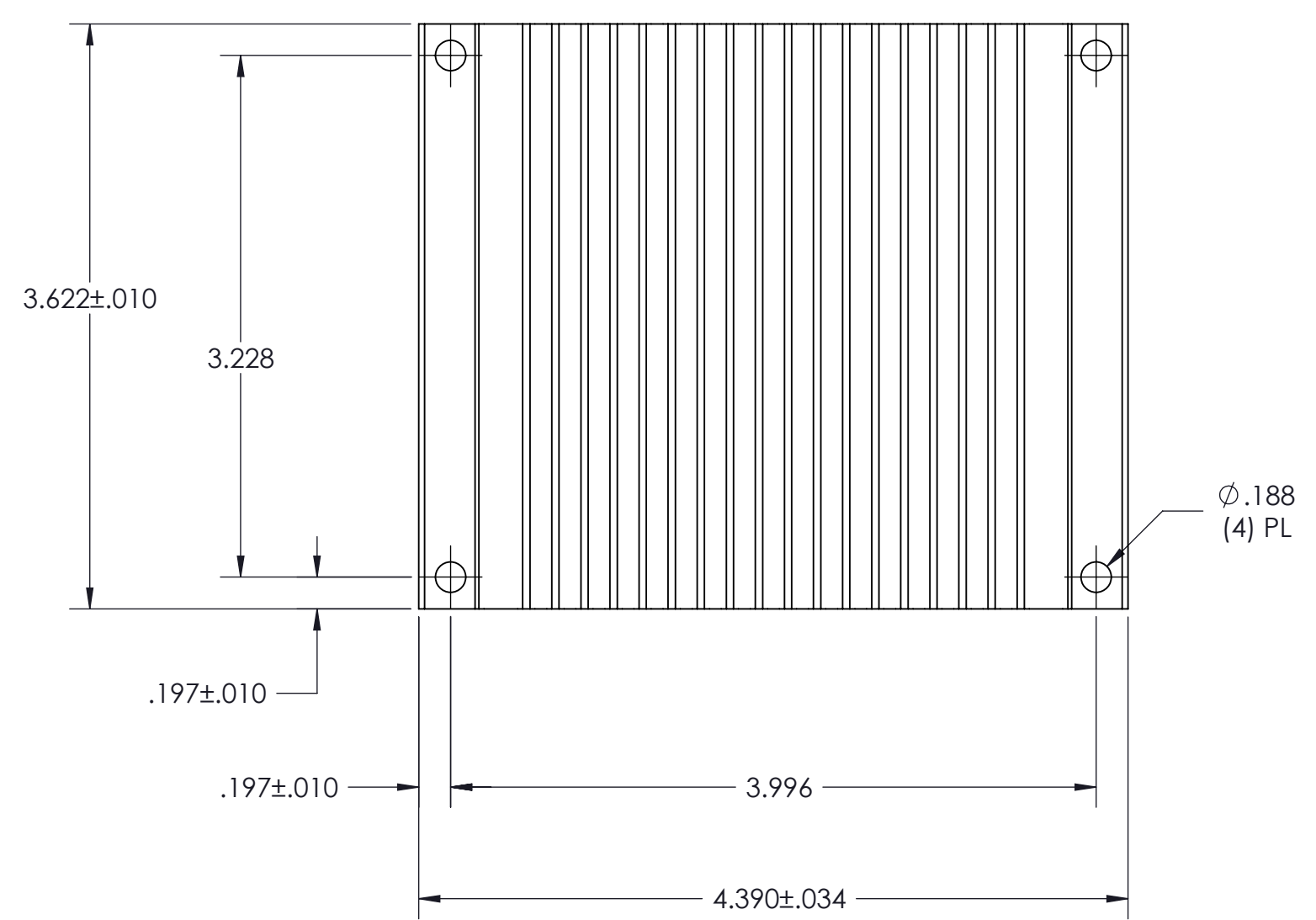
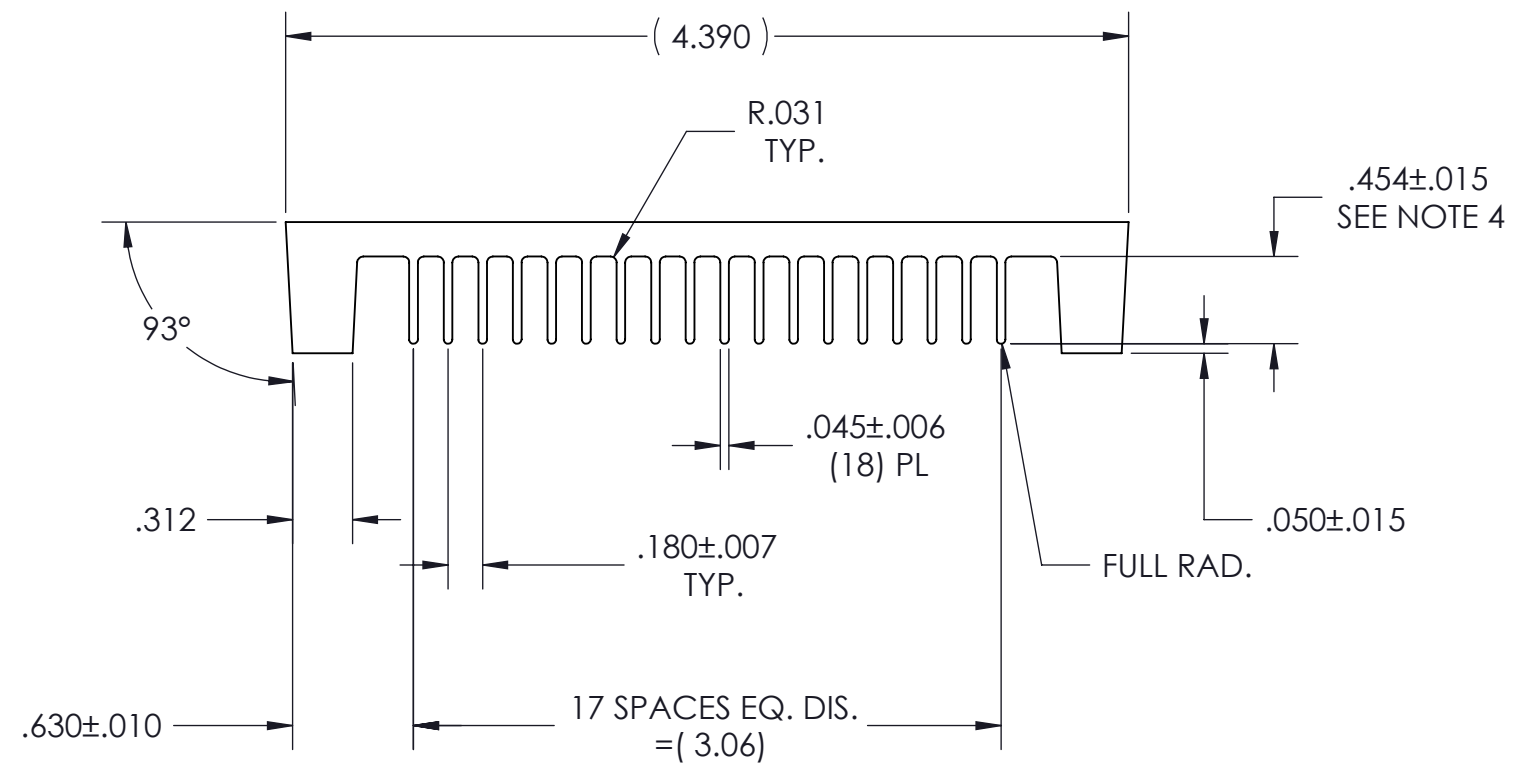

- NOTES:
1. MATERIAL: ALUMINUM 6063-T5
 2. REMOVE ALL BURRS AND SHARP EDGES.
 3. CLEAR FINISH, RoHS COMPLIANT, CHROMIUM FREE PER CST-001 LATEST REVISION.
 4. TOLERANCE ON DIMENSION INDICATED TO ALLOW FOR CROWN OF RAW STOCK.
 5. NO MACHINING MISMATCH PERMITTED THIS SURFACE.
 6. NOTES 3 AND 5 ARE CRITICAL CHARACTERISTIC FOR LOT INSPECTION.
 7. VICOR WORKMANSHIP SPECIFICATIONS WS-0003 AND WS-0007 APPLY TO THE FABRICATION OF THIS ITEM.
 8. DIMENSIONS ARE INCHES ONLY.

DRAWN	DATE				
P.E.IENI	12/08/05				
MATERIAL	UNLESS OTHERWISE SPECIFIED DIMENSIONS ARE INCH [MM]	F/A HS CFG "G" & "H" XFLOW ARRAY (VIPAC)			
FINISH	THIRD ANGLE PROJECTION				
		SIZE	CAGE CODE	DWG NO	REV
DO NOT SCALE DRAWING		C	67131	32180	2
SCALE 2 : 1			SHEET 1 OF 1		