

**VICOR CONFIDENTIAL**

THIS DOCUMENT AND THE DATA DISCLOSED HEREIN OR HEREWITH IS NOT TO BE REPRODUCED, USED, OR DISCLOSED IN WHOLE OR IN PART TO ANYONE WITHOUT PERMISSION OF VICOR CORP.

REV.	DESCRIPTION	DATE	APPROVED
1	RELEASED PER E050374	01/04/06	ECF
2	REVISED PER E060602	03/16/06	ECF

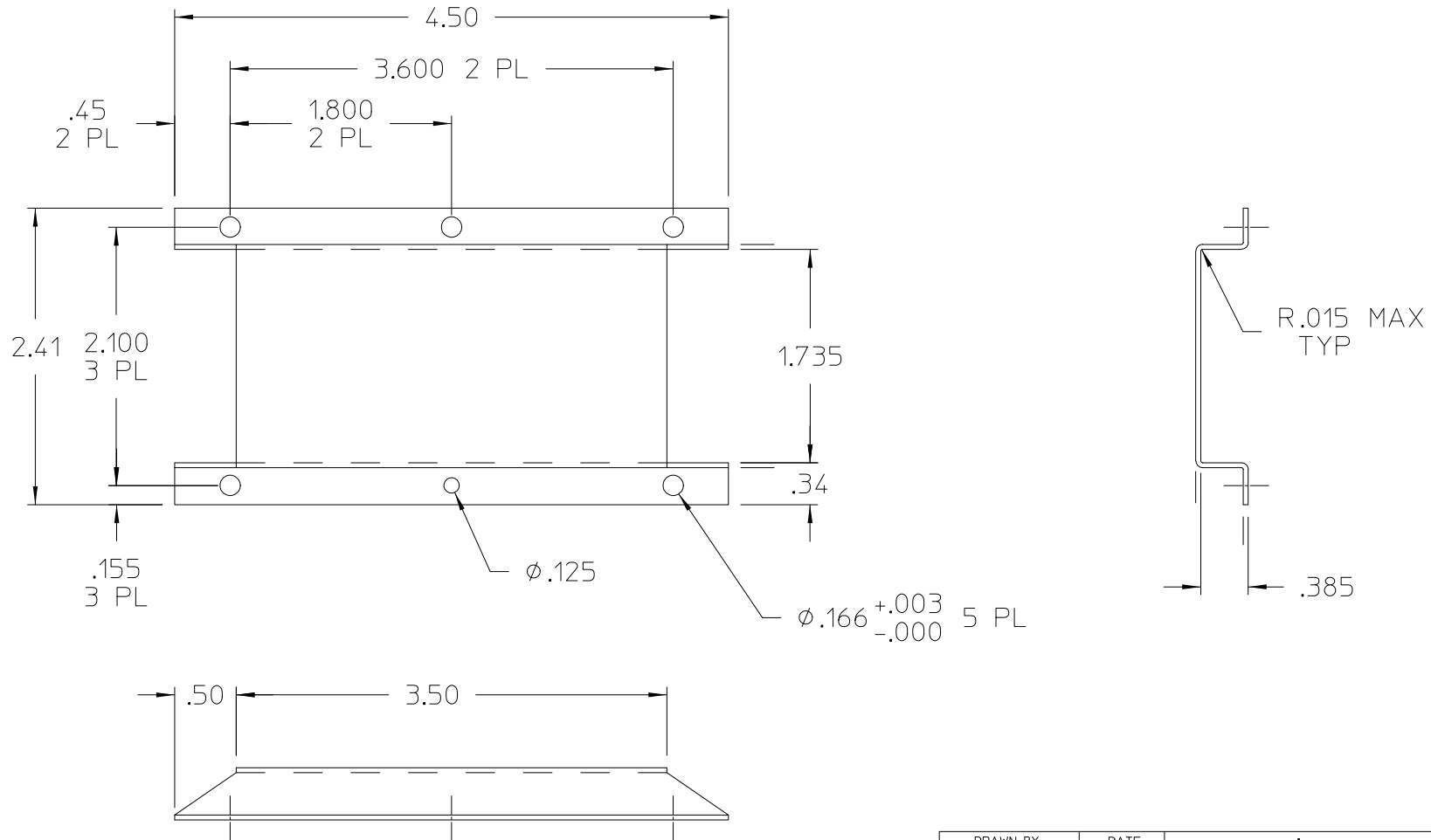

**NOTES**

1. MATERIAL: 5052-H32 ALUMINUM, .040 THICK.
2. CLEAR FINISH, RoHS COMPLIANT, CHROMIUM FREE PER CST-0001 LATEST REVISION.
3. REMOVE ALL BURRS AND BREAK SHARP EDGES.

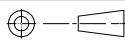
DRAWN BY <i>P.E.IENI</i>		DATE 12/06/05		 <b>MODULE SHIELD W/O PEM NUTS VI-200</b>	
<small>UNLESS OTHERWISE SPECIFIED DIMENSIONS ARE IN INCHES - TOLERANCES ARE:          FRACTIONS DECIMALS ANGLES          *1/64 .XX=+.01 ±1°          .XXX=+.005</small>					
THIRD ANGLE PROJECTION 		SIZE <b>B</b>	FSCM NO. <b>67131</b>	DWG NO <b>32175</b>	REV <b>2</b>
DO NOT SCALE DRAWING		SCALE FULL	SHEET 1 OF 1		