

THIS DOCUMENT AND THE DATA DISCLOSED HEREIN OR HEREWITH IS NOT TO BE REPRODUCED, USED OR DISCLOSED IN WHOLE OR IN PART TO ANYONE WITHOUT THE PERMISSION OF VICOR CORP.

REVISIONS

REV	DESCRIPTION	DATE	APPROVED
1	RELEASED PER E050372	1/04/06	ECF
2	REVISED PER E100841	06/22/10	GCK

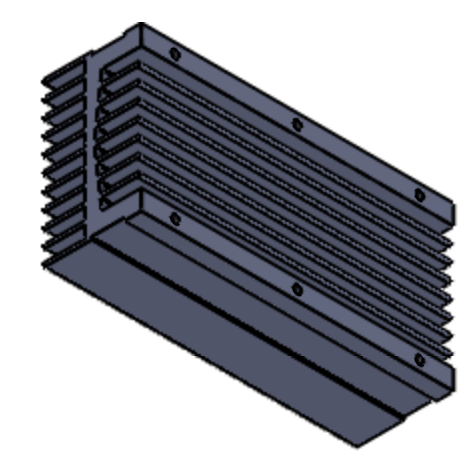
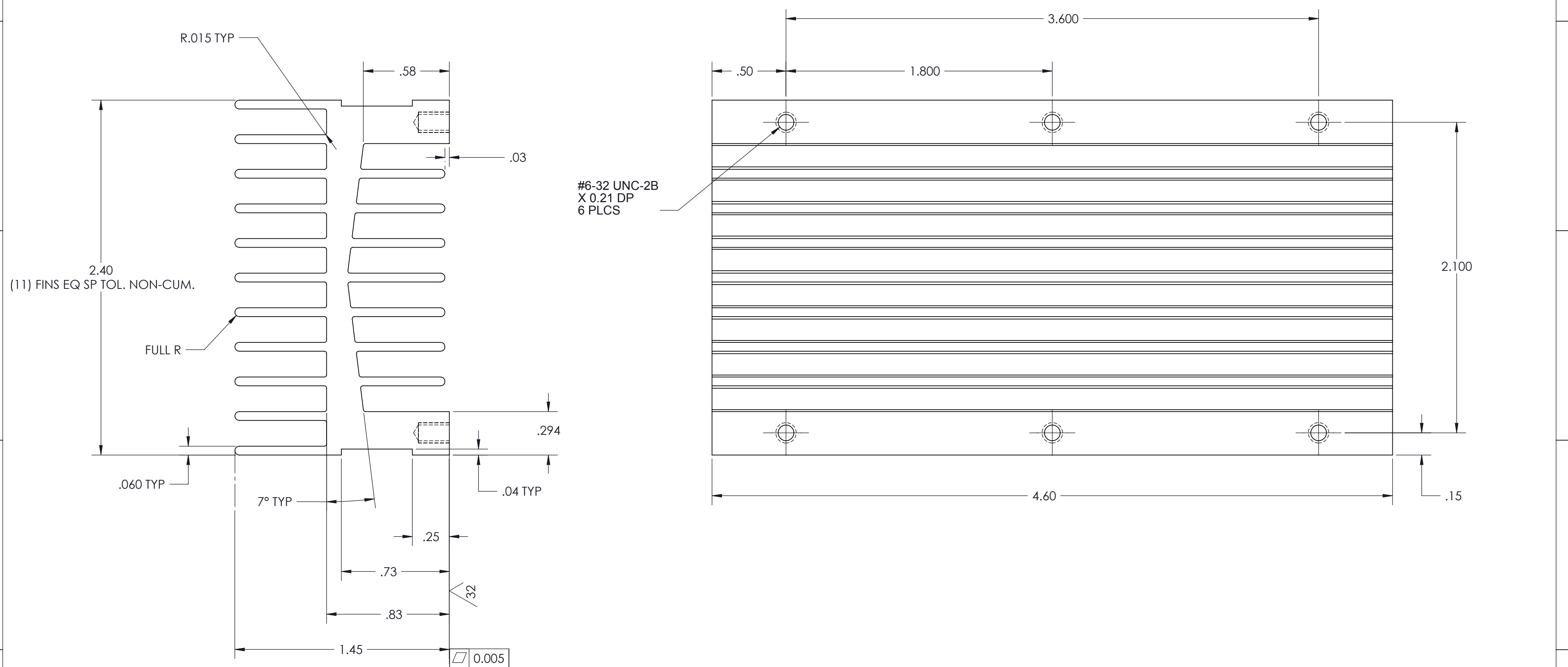

NOTES:

1. MATERIAL: AL. 6063-T6.
2. REMOVE ALL LOOSE AND HANGING BURRS. OTHERWISE, BURRS SHALL NOT EXCEED .003.
3. CLEAR FINISH, RoHS COMPLIANT, CHROMIUM FREE PER CST-0001, LATEST REVISION.
4. PERMANENTLY MARK PART NUMBER AND REVISION LEGIBLY IN AREA SHOWN.
5. ○ DENOTES CRITICAL CHARACTERISTIC FOR LOT INSPECTION.
6. TOLERANCE ON ALL DIMENSIONS SHOWN AS REFERENCE SHALL FOLLOW STANDARD ALUMINUM ASSOCIATION TOLERANCE.

DRAWN	DATE				
P.E.IENI	11/16/05				
MATERIAL	UNLESS OTHERWISE SPECIFIED DIMENSIONS ARE INCH [MM]	<p>HEATSINK EXTRUSION</p>			
FINISH	THIRD ANGLE PROJECTION				
<p>UNLESS OTHERWISE SPECIFIED DIMENSIONS ARE INCH [MM]</p> <p>TOLERANCES ARE:</p> <p>DECIMALS ANGLES</p> <p>X.XX [X.X] = ±0.01 [0.25] ±1°</p> <p>X.XXX [X.XX] = ±0.005 [0.127]</p>		SIZE	CAGE CODE	DWG NO	REV
<p>DO NOT SCALE DRAWING</p>		C	67131	30780	2
		SCALE 2 : 1		SHEET 1 OF 1	