

THIS DOCUMENT AND THE DATA DISCLOSED HEREIN OR HEREWITH IS NOT TO BE REPRODUCED, USED OR DISCLOSED IN WHOLE OR IN PART TO ANYONE WITHOUT THE PERMISSION OF VICOR CORP.

REVISIONS

REV	DESCRIPTION	DATE	APPROVED
1	RELEASED PER E053437	LEK 11/15/05	EF
2	REVISED PER E090943	AR 06/03/09	REJH
3	REDRAWN PER E100871	DCS 6/8/10	KUK

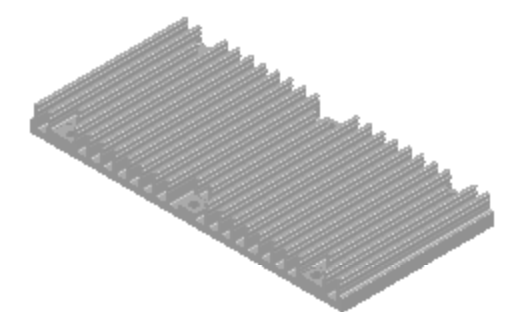
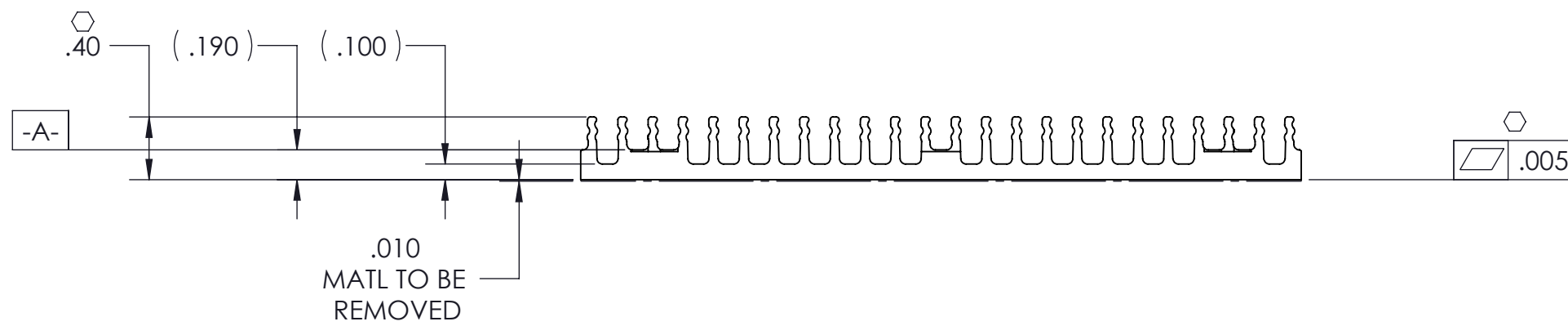
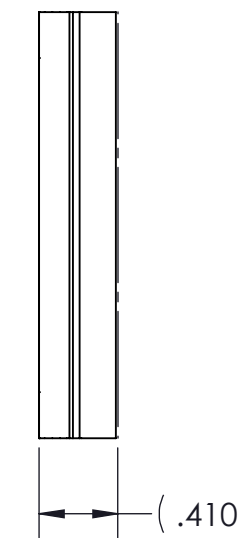
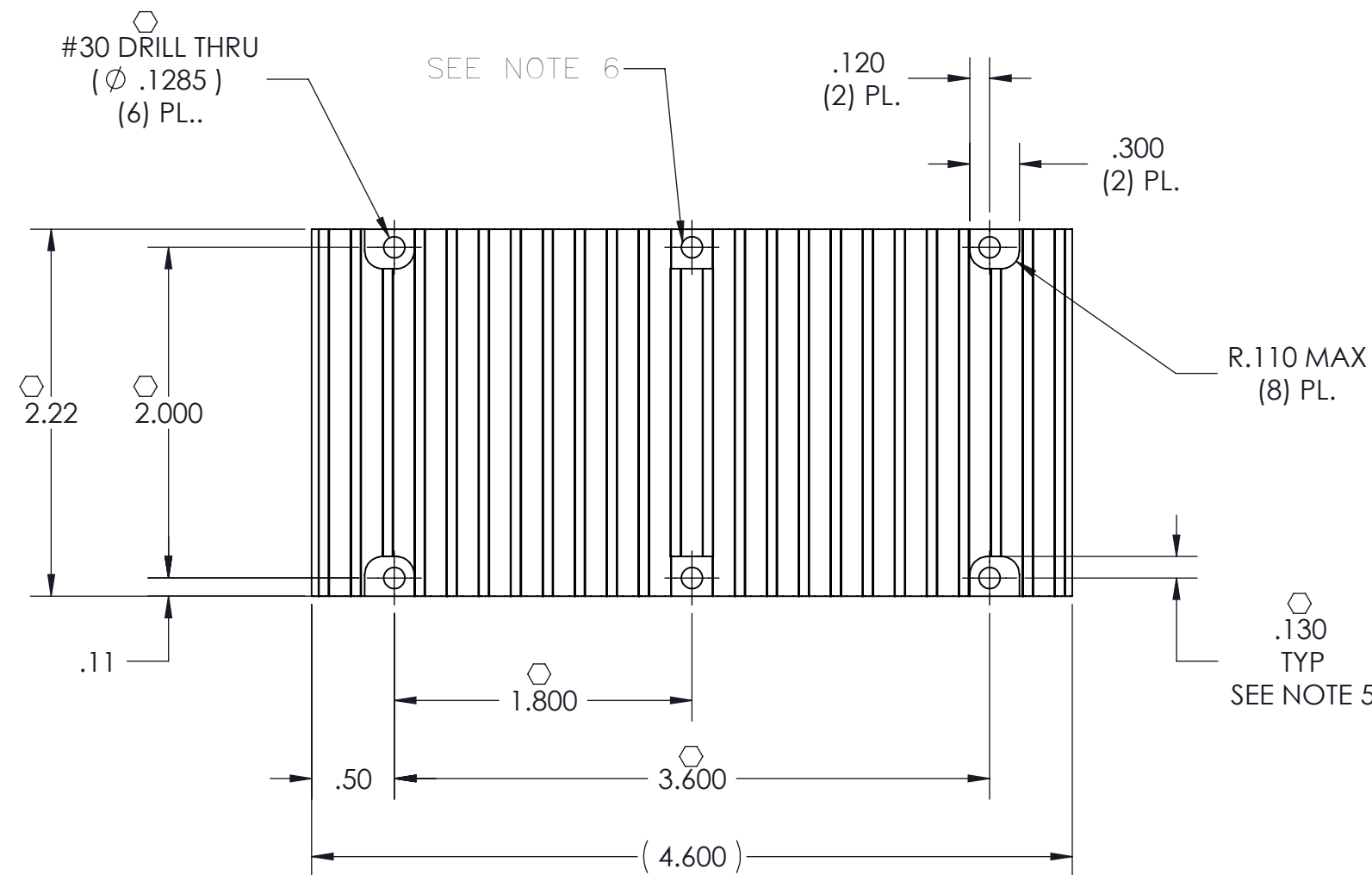

NOTES:

1. MATERIAL: EXTRUSION SEE SHEET 2 OF 2
2. REMOVE ALL BURRS AND SHARP EDGES.
3. CLEAR FINISH, RoHS COMPLIANT, CHROMIUM FREE PER CST-0001 LATEST REVISION.
4. "⊕" DENOTES CRITICAL CHARACTERISTIC FOR LOT INSPECTION.
5. DIMENSIONS APPLIES AT SURFACE -A- (2) PL.
6. MACHINED SURFACE TO BE .010 MAX BELOW SURFACE -A- (6) PLACES.
7. DIMENSIONS ARE INCHES ONLY

DRAWN D.P. KELLY		DATE 10/05		SWD	
MATERIAL SEE NOTES		UNLESS OTHERWISE SPECIFIED DIMENSIONS ARE INCH [MM] TOLERANCES ARE: DECIMALS ANGLES X.XX [X.X] = ±0.01 [0.25] ±1° X.XXX [X.XX] = ±0.005 [0.127]		HS CFG "A" .4H X-FLOW LOW FLOW THRU HOLE	
FINISH SEE NOTES		THIRD ANGLE PROJECTION 		SIZE C	CAGE CODE 67131
		DO NOT SCALE DRAWING		DWG NO 30720	REV 3
				SCALE 1 : 1 SHEET 1 OF 1	

THIS DOCUMENT AND THE DATA DISCLOSED HEREIN OR HEREWITH IS NOT TO BE REPRODUCED, USED OR DISCLOSED IN WHOLE OR IN PART TO ANYONE WITHOUT THE PERMISSION OF VICOR CORP.

REV	DESCRIPTION	DATE	APPROVED
	SEE SHEET 1 OF 2		

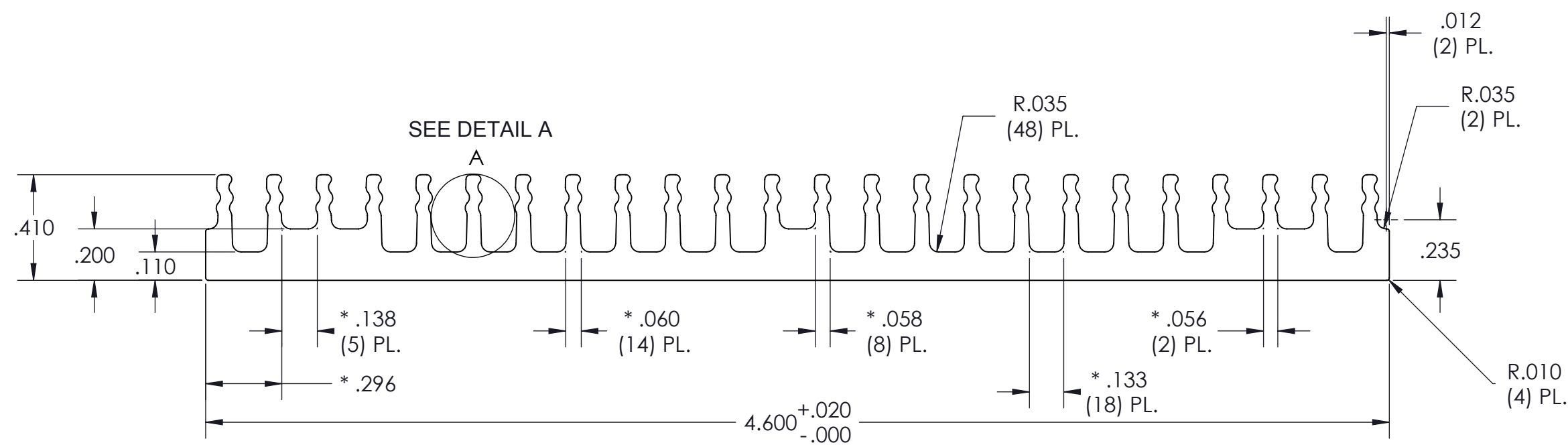

PROFILE COMMON FOR
30778
30720

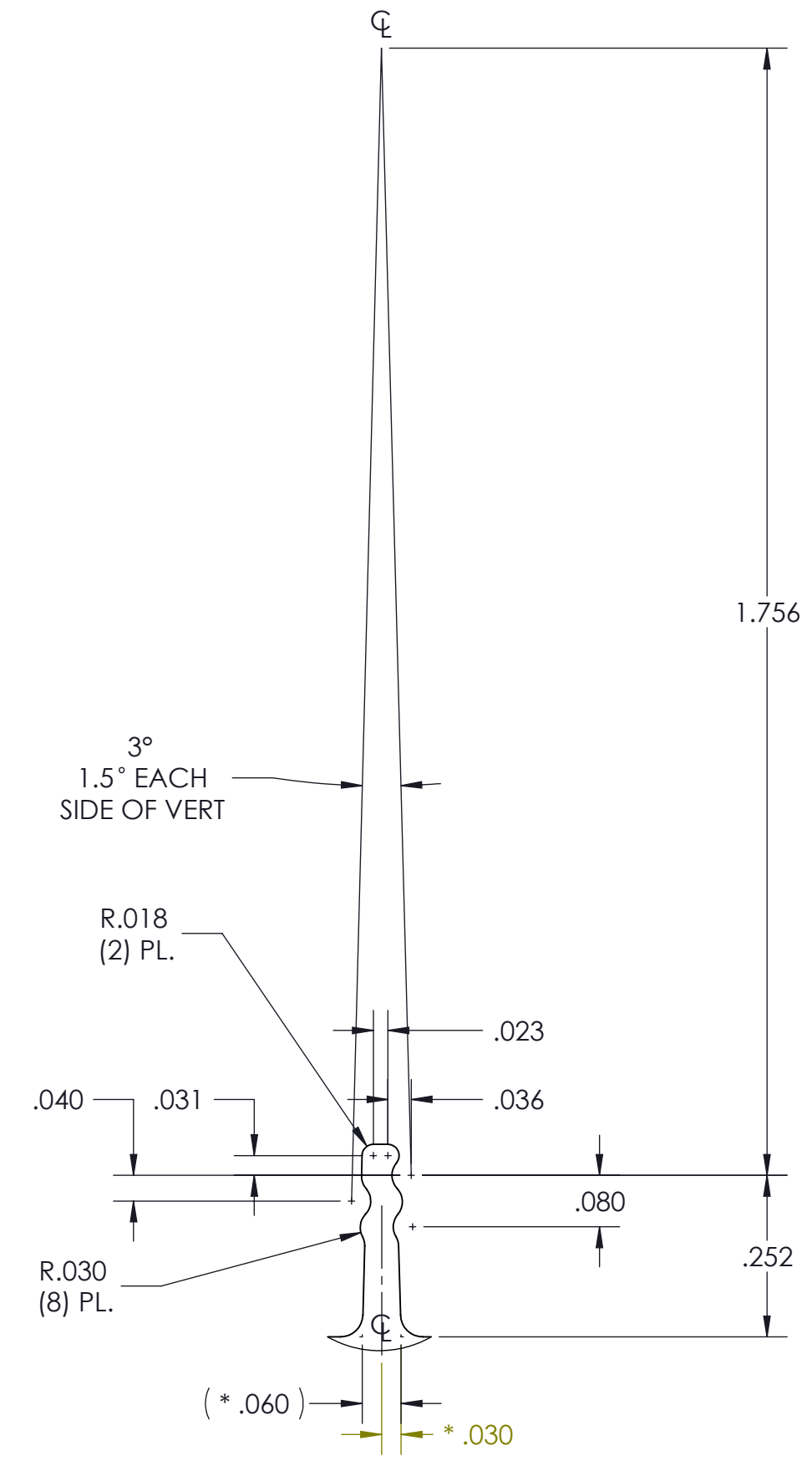

DETAIL A
SCALE 4 : 1

NOTES:

1. MAT'L: ALUMINUM 6063-T5
2. *DENOTES DIMENSION TO THEORETICAL SHARP CORNER
3. DIMENSIONS ARE INCHES ONLY

DRAWN	DATE				
A. RAGIPANI	06/03/09				
MATERIAL	UNLESS OTHERWISE SPECIFIED DIMENSIONS ARE INCH [MM]	HS CFG "A" .4H X-FLOW, LOW FLOW THRU HOLE, EXTRUSION			
XXXXX	TOLERANCES ARE: DECIMALS ANGLES X.XX [X.X] = ±0.01 [0.25] ±1° X.XXX [X.XX] = ±0.005 [0.127]				
FINISH	THIRD ANGLE PROJECTION	SIZE	CAGE CODE	DWG NO	REV
XXXXX		C	67131	30720	3
DO NOT SCALE DRAWING		SCALE 2 : 1		SHEET 2 OF 2	