

THIS DOCUMENT AND THE DATA DISCLOSED HEREIN OR HEREWITH IS NOT TO BE REPRODUCED, USED, OR DISCLOSED IN WHOLE OR IN PART TO ANYONE WITHOUT PERMISSION OF VICOR CORP.

REV.	DESCRIPTION	DATE	APPROVED
1	RELEASED PER E050316	LEK 10/26/05	SH
2	REVISED PER E160690	GCK 08/02/16	MTB

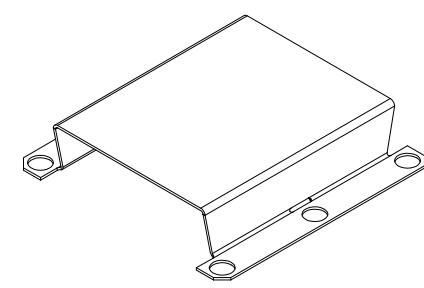
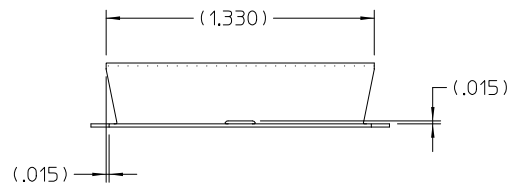
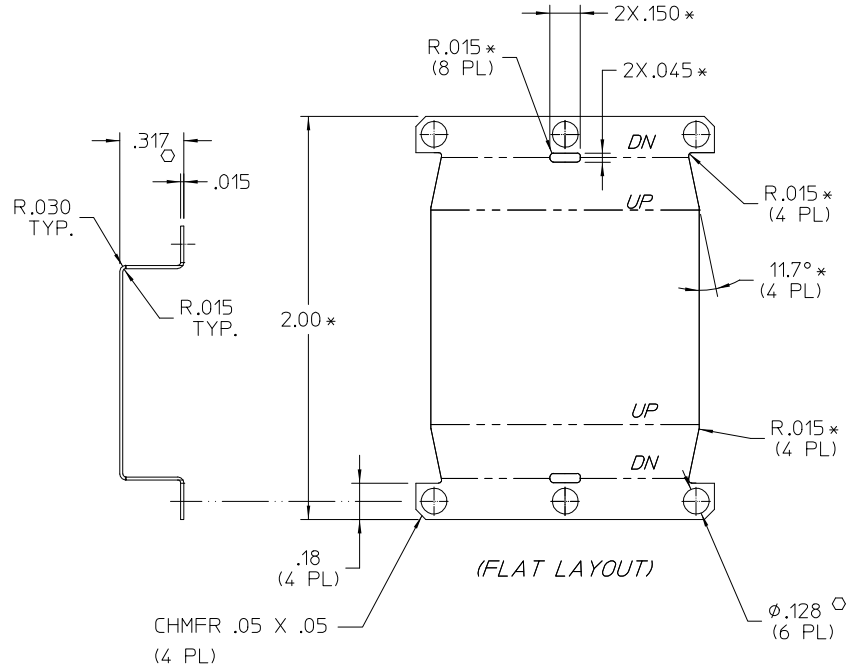
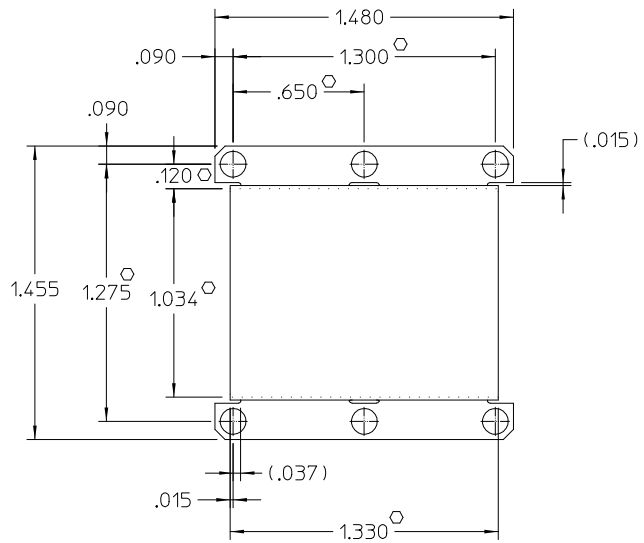

- NOTES:
1. MATERIAL: ALUMINUM-(.015) THK, 3003-H14
 2. REMOVE BURRS & SHARP EDGES
 3. "*" DIMENSIONS ARE NOT FOR VICOR INSPECTION,"
 4. O DENOTES CRITICAL CHARACTERISTICS FOR LOT INSPECTION.
 5. CLEAR FINISH, ROHS COMPLIANT PER CST-0001 LATEST REVISION.
 - A.) CHROMIUM FREE, OR
 - B.) TRIVALENT CHROMIUM IN ACCORDANCE WITH MIL-DTL-5541, TYPE II, CLASS 1A OR 3. SEE CST-0003 FOR TYPES OF AVAILABLE FINISHES.

DRAWN BY <i>P.E.IENI</i>	DATE 05/25/05			
<small>UNLESS OTHERWISE SPECIFIED DIMENSIONS ARE IN INCHES - TOLERANCES ARE:</small> FRACTIONS DECIMALS ANGLES +1/64 .XX+ .01 *1° .XXX+.005				
THIRD ANGLE PROJECTION	SIZE C	FSCM NO. 67131	DWG NO. 30143	REV 2
DO NOT SCALE DRAWING	SCALE 2:1	SHEET 1 OF 1		