

VICOR CONFIDENTIAL
 THIS DOCUMENT AND THE DATA DISCLOSED HEREIN OR
 HEREWITH IS NOT TO BE REPRODUCED, USED OR
 DISCLOSED IN WHOLE OR IN PART TO ANYONE WITHOUT
 THE PERMISSION OF VICOR CORP.

REV.	DESCRIPTION	DATE	APPROVED
1	RELEASED PER E053437	LEK 11/15/05	EF
2	REVISED PER E091085	AR 07/10/09	REJH
3	REDRAWN PER E100887	DCS 6/8/10	KUK
4	REVISED PER E120702	ZMB 07/31/12	REJH

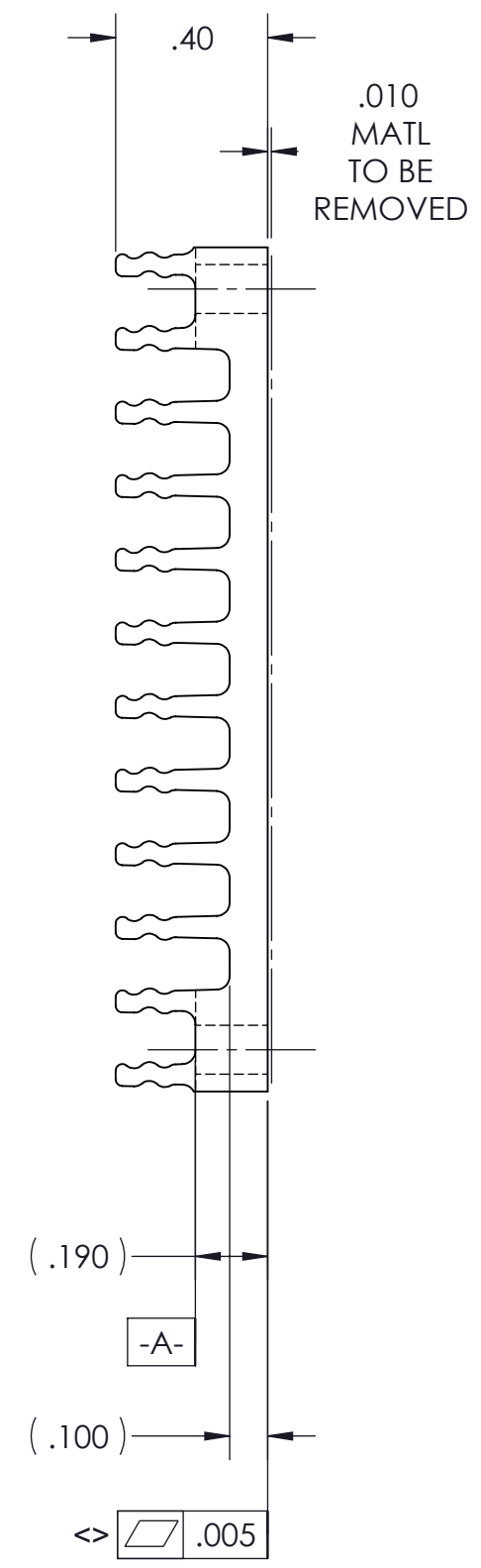

- NOTES:
1. MATERIAL: EXTRUSION SEE SHEET 2 OF 2.
 2. REMOVE ALL BURRS AND SHARP EDGES.
 3. CLEAR FINISH, RoHS COMPLIANT PER CST-0001, LATEST REVISION PER A.) CHROMIUM FREE, OR B.) TRIVALENT CHROMIUM IN ACCORDANCE WITH MIL-DTL-5541, TYPE II, CLASS 1A OR 3. SEE CST-0003 FOR TYPES OF AVAILABLE FINISHES.
 4. "<>" DENOTES CRITICAL CHARACTERISTIC FOR LOT INSPECTION
 5. DIMENSIONS APPLIES AT SURFACE -A- (12) PL.
 6. MACHINED SURFACE TO BE .010 MAX BELOW SURFACE -A- (6) PL.
 7. DIMENSIONS ARE INCHES ONLY.

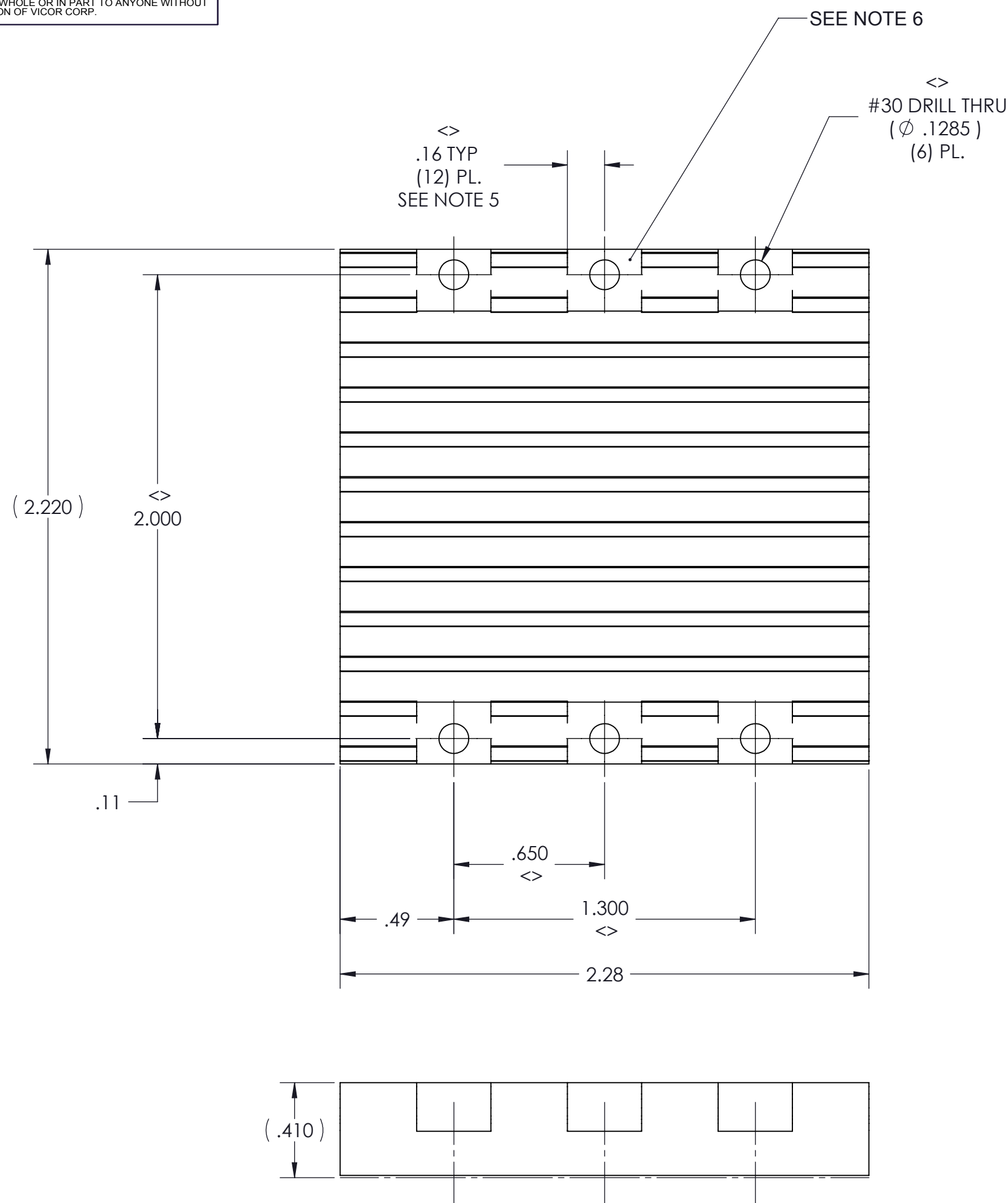
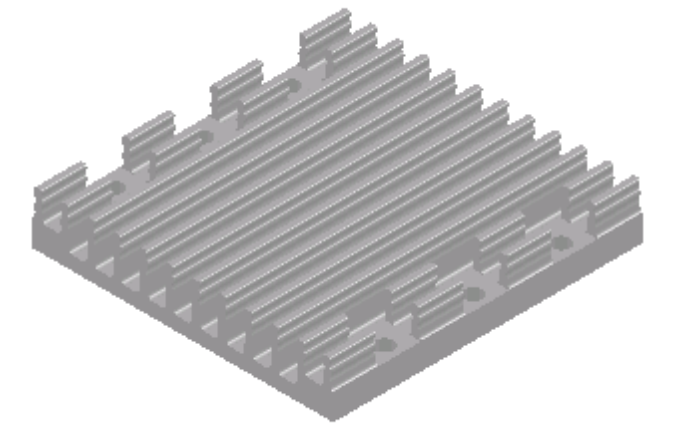

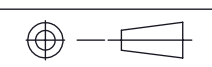
DRAWN BY P.E. IENI	DATE 06/30/05	VICOR SWD			
UNLESS OTHERWISE SPECIFIED DIMENSIONS ARE : INCH / (MM)		HS CFG "B" LONG .4H LOW FLOW, THRU HOLE			
TOLERANCES ARE: DECIMALS ANGLES X.XX [X.X] = ±0.01 [0.25] ±1° X.XXX [X.XXX] = ±0.005 [0.127]		SIZE C	CAGE CODE 67131	DWG NO 30195	REV 4
THIRD ANGLE PROJECTION  DO NOT SCALE DRAWING		SCALE 2:1		SHEET 1 OF 2	

VICOR CONFIDENTIAL

THIS DOCUMENT AND THE DATA DISCLOSED HEREIN OR HEREWITH IS NOT TO BE REPRODUCED, USED OR DISCLOSED IN WHOLE OR IN PART TO ANYONE WITHOUT THE PERMISSION OF VICOR CORP.

REVISIONS

REV	DESCRIPTION	DATE	APPROVED
	SEE SHEET 1		

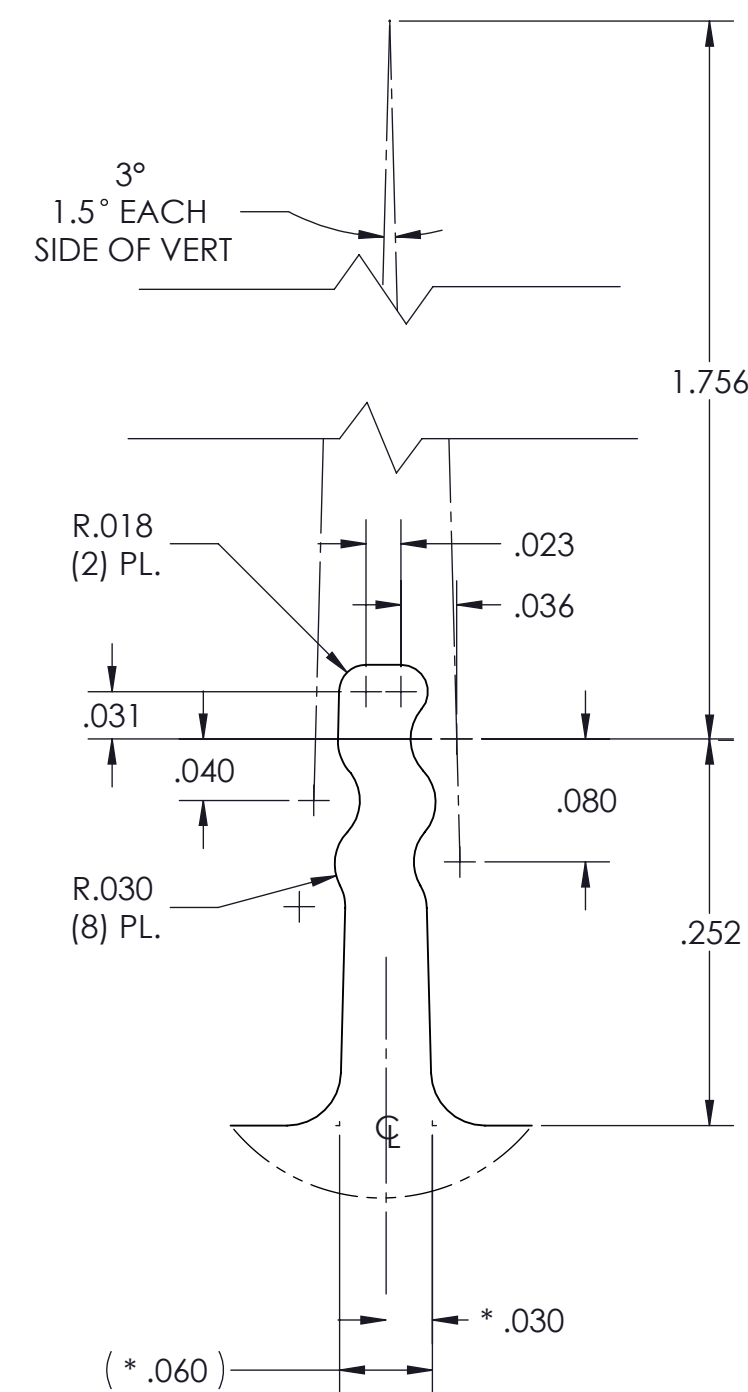
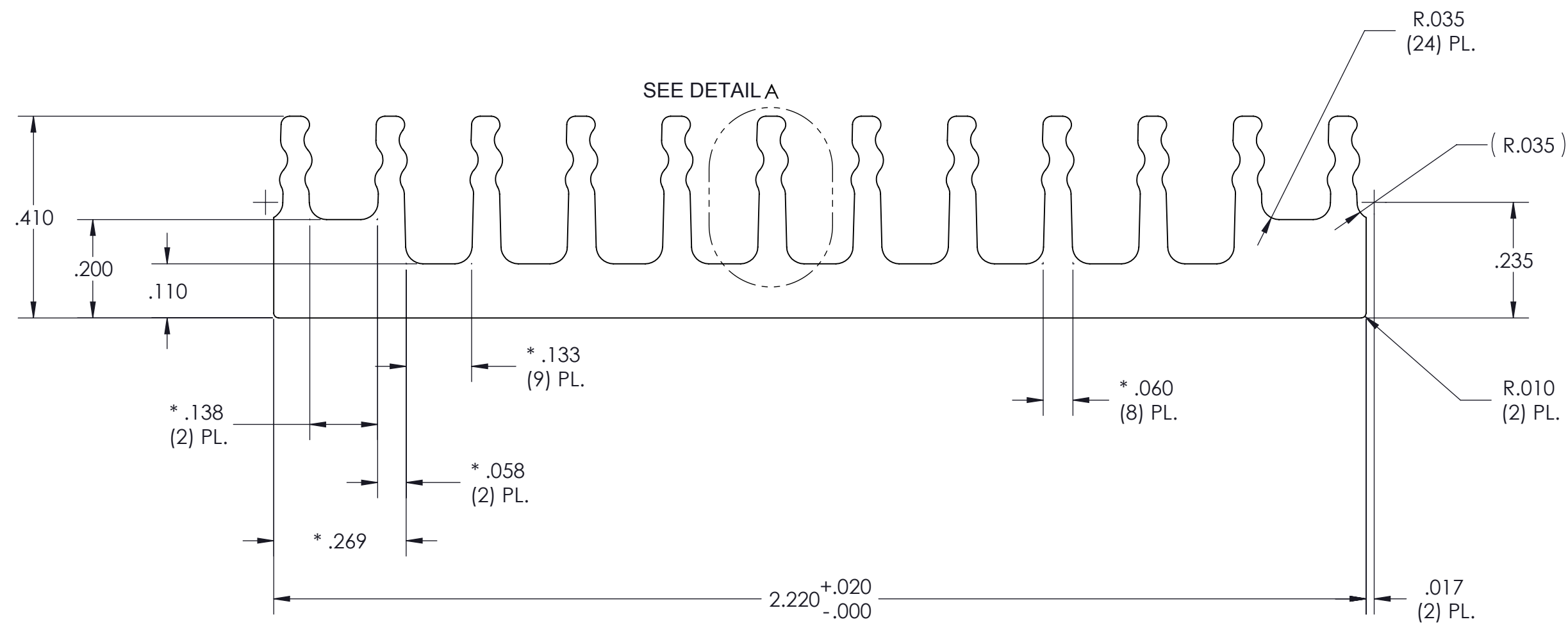

DETAIL A
SCALE 8 : 1

PROFILE COMMON FOR
30195
30718
32188
30482

NOTES:

- MATL: ALUMINUM 6063-T5
- * DENOTES DIMENSION TO THEORETICAL SHARP CORNER.
- ALL DIMENSIONS ARE CRITICAL CHARACTERISTICS
- RoHS COMPLIANT PER CST-0001 LATEST REVISION.
- DIMENSIONS ARE INCHES ONLY

DRAWN BY A. RAGIPANI	DATE 07/10/09	SWD	
UNLESS OTHERWISE SPECIFIED DIMENSIONS ARE : INCH / [MM]		HS CFG "B" LONG .4H LOW FLOW, THRU HOLE, EXTRUSION	
TOLERANCES ARE: DECIMALS ANGLES X.XX [X.X] = ±0.01 [0.25] ±1° X.XXX [X.XX] = ±0.005 [0.127]			
THIRD ANGLE PROJECTION 	SIZE C	CAGE CODE 67131	DWG NO 30195
DO NOT SCALE DRAWING	SCALE 2:1	REV 4	SHEET 2 OF 2