

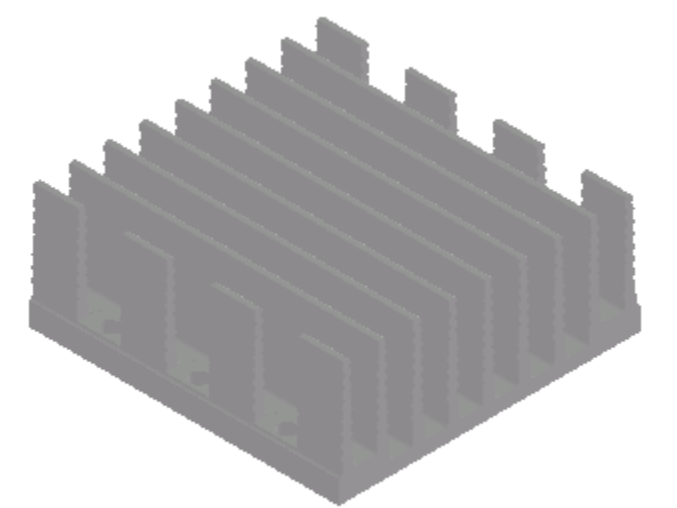

VICOR CONFIDENTIAL
 THIS DOCUMENT AND THE DATA DISCLOSED HEREIN OR
 HEREWITH IS NOT TO BE REPRODUCED, USED OR
 DISCLOSED IN WHOLE OR IN PART TO ANYONE WITHOUT
 THE PERMISSION OF VICOR CORP.

REV.	DESCRIPTION	DATE	APPROVED
3	RELEASED PER E090033	AR	01/09/09
4	REVISED PER E092035	JS	11/16/09
5	REDRAWN PER E100871	DCS	07/01/10
6	REVISED PER E111266	VSS	12/22/11
7	REVISED PER E120702	ZMB	07/31/12

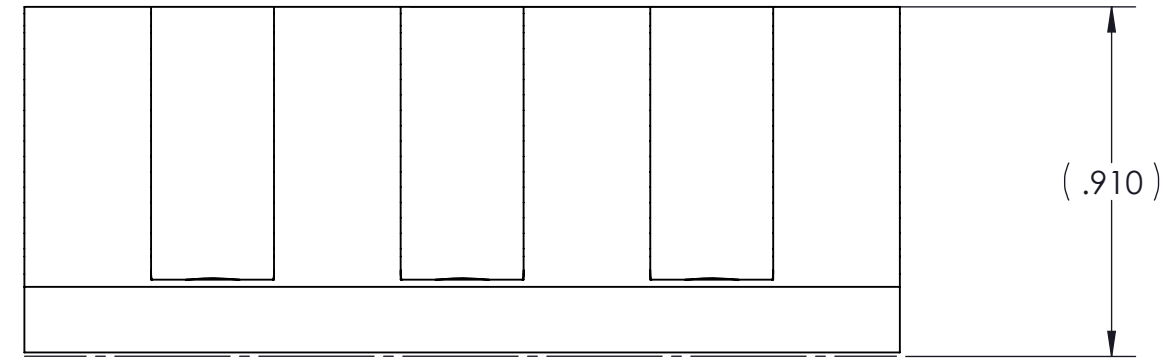
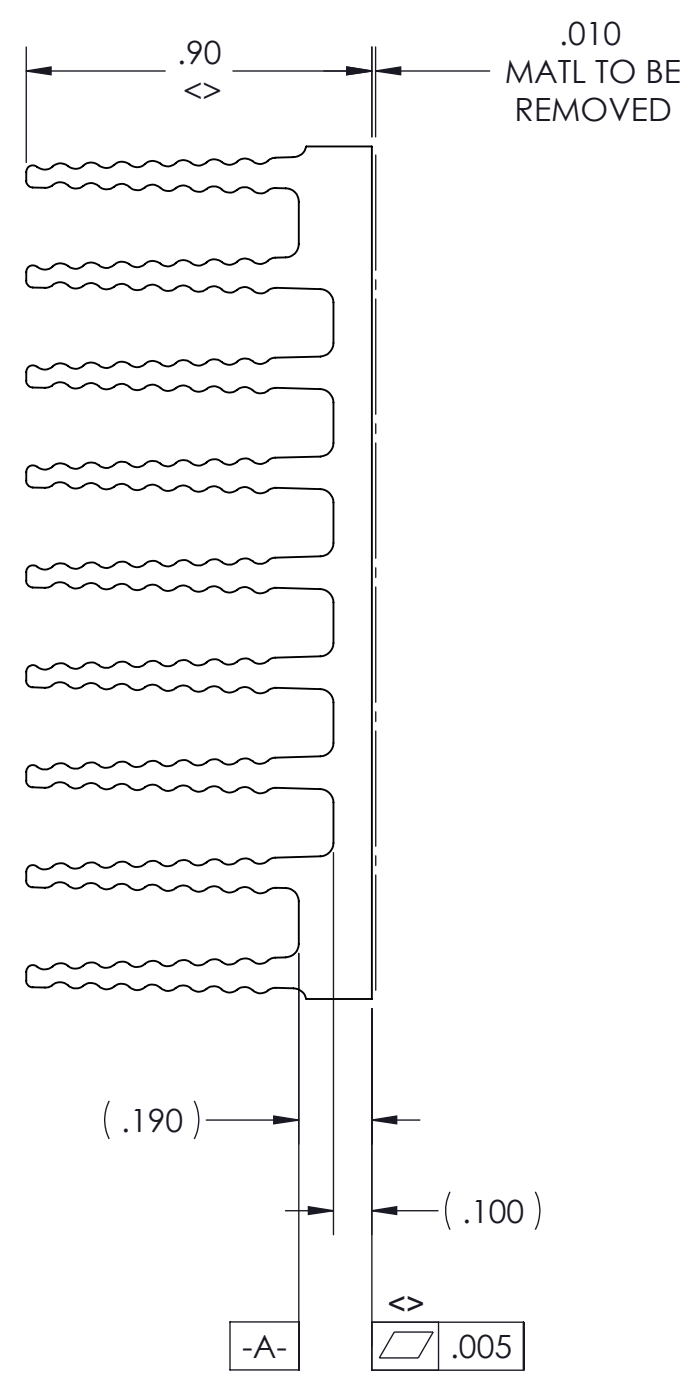
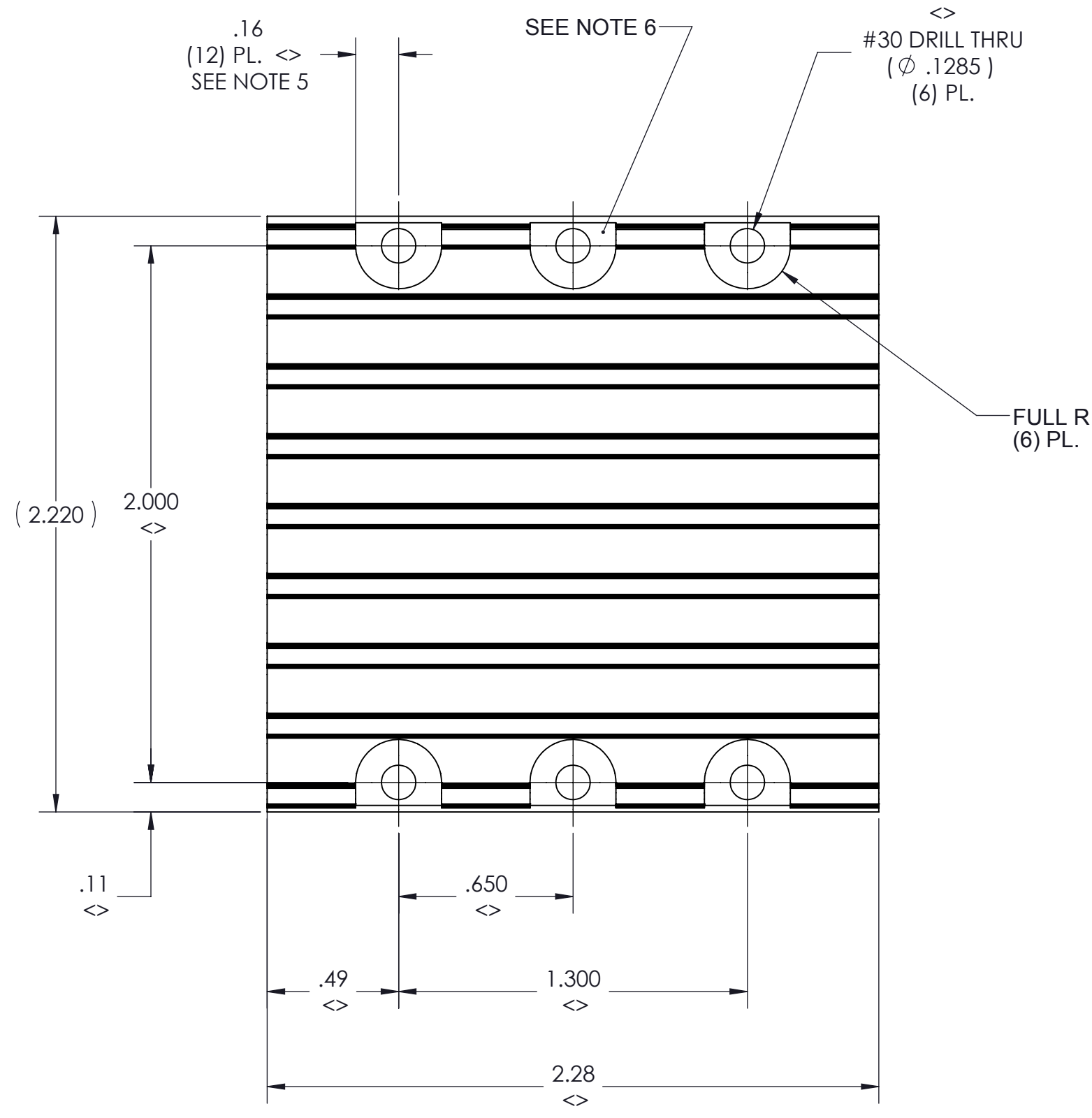

- NOTES:
1. MATERIAL: EXTRUSION SEE SHEET 2 OF 2.
 2. REMOVE ALL BURRS AND SHARP EDGES.
 3. CLEAR FINISH, RoHS COMPLAINT PER CST-0001, LATEST REVISION PER A)CHROMIUM FREE, OR B)TRIVALENT CHROMIUM IN ACCORDANCE WITH MIL-DTL-5541, TYPE II, CLASS 1A OR 3. SEE CST-0003 FOR TYPES OF AVAILABLE FINISHES
 4. " <> " DENOTES CRITICAL CHARACTERISTIC FOR LOT INSPECTION.
 5. DIMENSIONS APPLIES AT SURFACE -A- (2) PL.
 6. MACHINED SURFACE TO BE .010 MAX BELOW SURFACE -A- (6) PL.
 7. DIMENSIONS ARE INCHES ONLY.

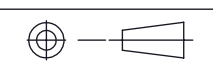
DRAWN BY	DATE			SWD
Robert Hickey	07/01/2010			HS "B" LONG .9H LF THRU HL
<small>UNLESS OTHERWISE SPECIFIED DIMENSIONS ARE : INCH / (MM)</small>		<small>TOLERANCES ARE: DECIMALS ANGLES</small> <small>X.XX [X.X] = ±0.01 [0.25] ±1°</small> <small>X.XXX [X.XX] = ±0.005 [0.127]</small>		
THIRD ANGLE PROJECTION	SIZE	CAGE CODE	DWG NO	REV
	C	67131	30182	7
DO NOT SCALE DRAWING	SCALE 2:1	SHEET 1 OF 2		

VICOR CONFIDENTIAL
 THIS DOCUMENT AND THE DATA DISCLOSED HEREIN OR
 HEREWITH IS NOT TO BE REPRODUCED, USED OR
 DISCLOSED IN WHOLE OR IN PART TO ANYONE WITHOUT
 THE PERMISSION OF VICOR CORP.

REV.	DESCRIPTION	DATE	APPROVED
	SEE SHEET 1 OF 2		

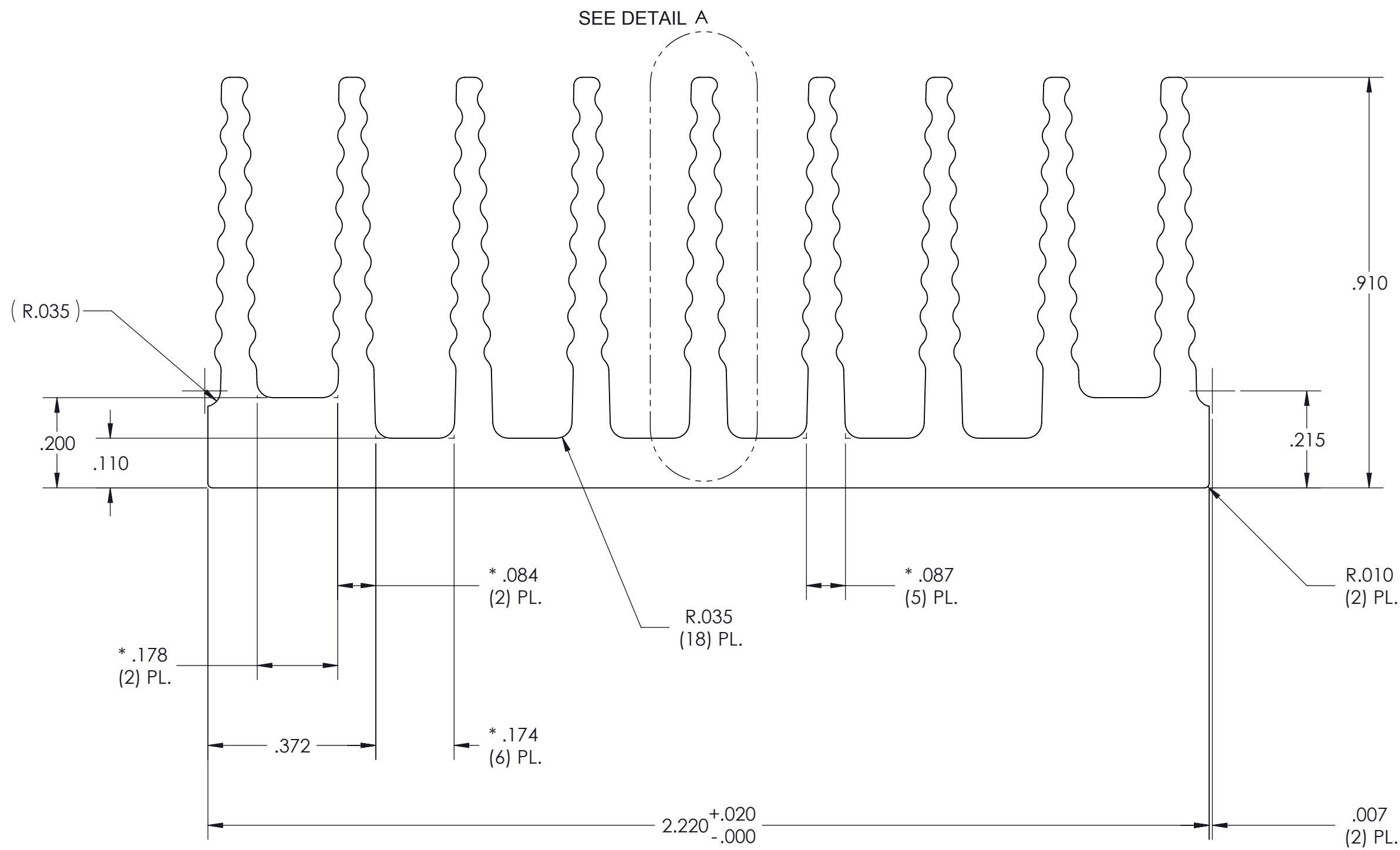

PROFILE COMMON FOR
30123
30181
30189
30182
30188

- NOTES:
1. MATERIAL: ALUMINUM 6063-T5
 2. * DENOTES DIMENSION TO THEORETICAL SHARP CORNER.
 3. ALL DIMENSIONS ARE CRITICAL CHARACTERISTICS.
 4. RoHS COMPLIANT PER CST-0001 LATEST REVISION.
 5. WORKMANSHIP STANDARDS WS-0004, WS-0006, AND WS0007 APPLY TO THIS PART.
 6. DIMENSIONS ARE INCHES ONLY.

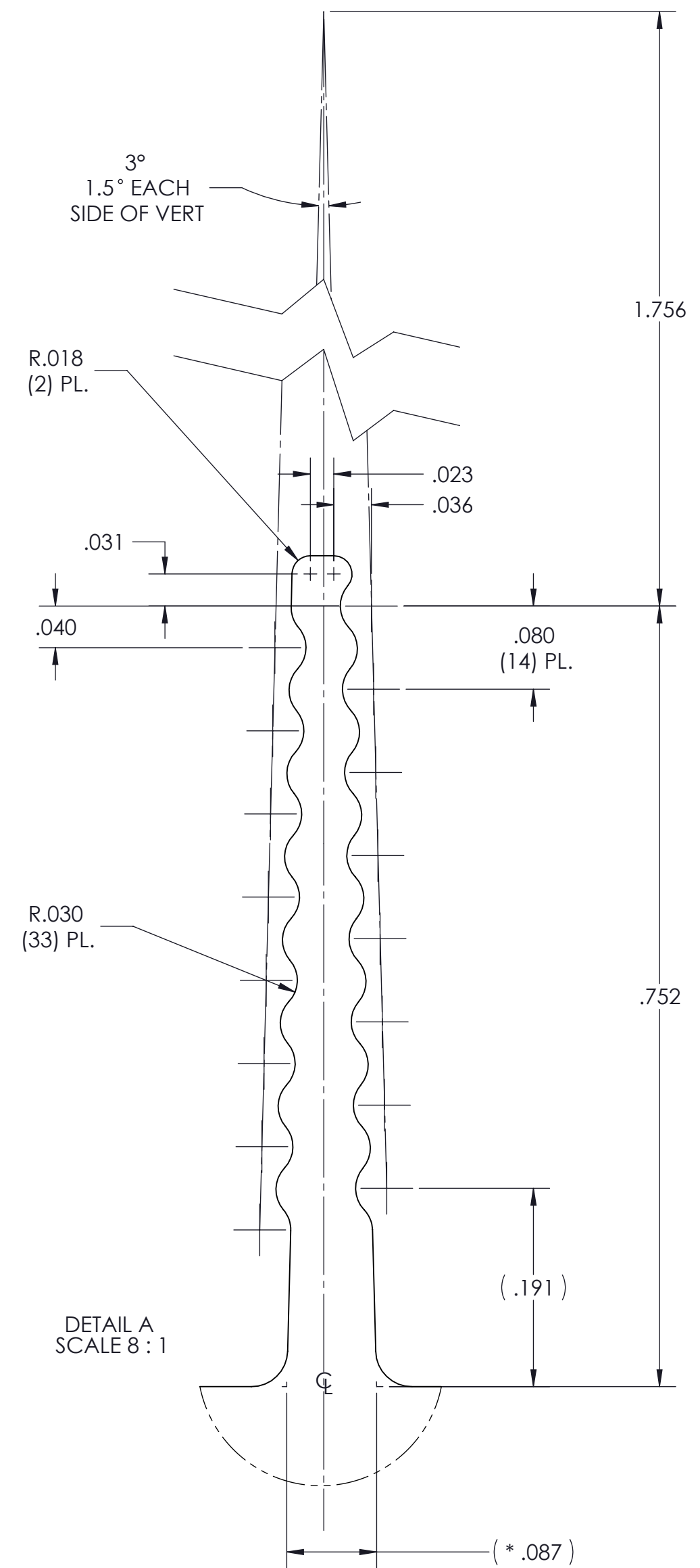

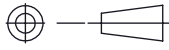
DRAWN BY Robert Hickey	DATE 07/01/2010	VICOR SWD			
UNLESS OTHERWISE SPECIFIED DIMENSIONS ARE : INCH / [MM]		HS "B" LONG .9H LF THRU HL EXTRUSION			
TOLERANCES ARE: DECIMALS ANGLES X.XX [X.X] = ±0.01 [0.25] ±1° X.XXX [X.XX] = ±0.005 [0.127]		SIZE C	CAGE CODE 67131	DWG NO 30182	REV 7
THIRD ANGLE PROJECTION 		SCALE 1:1		SHEET 2 OF 2	