

8

7

6

5

4

3

2

1

VICOR CONFIDENTIAL

THIS DOCUMENT AND THE DATA DISCLOSED HEREIN OR HEREWITH IS NOT TO BE REPRODUCED, USED OR DISCLOSED IN WHOLE OR IN PART TO ANYONE WITHOUT THE PERMISSION OF VICOR CORP.

REVISIONS

REV	DESCRIPTION	DATE	APPROVED
1	RELEASED PER E054248	11/15/05	ECF
2	REVISED PER E064283	02/24/06	ECF
3	REVISED PER E100799	06/14/10	GCK

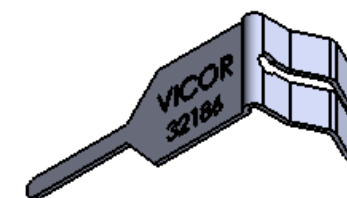
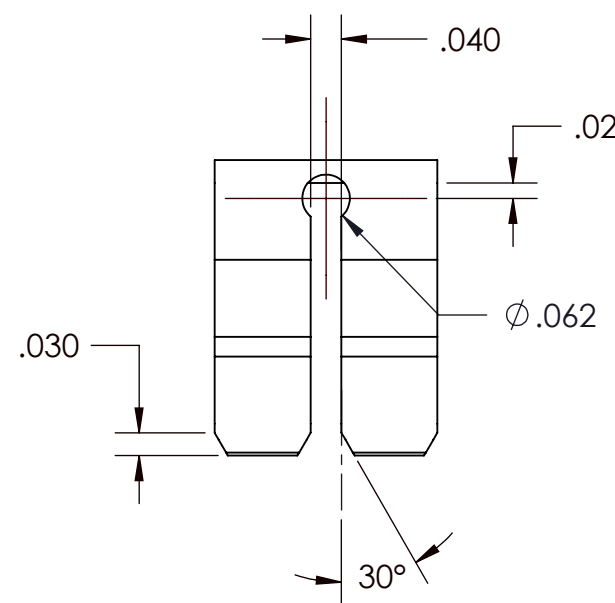
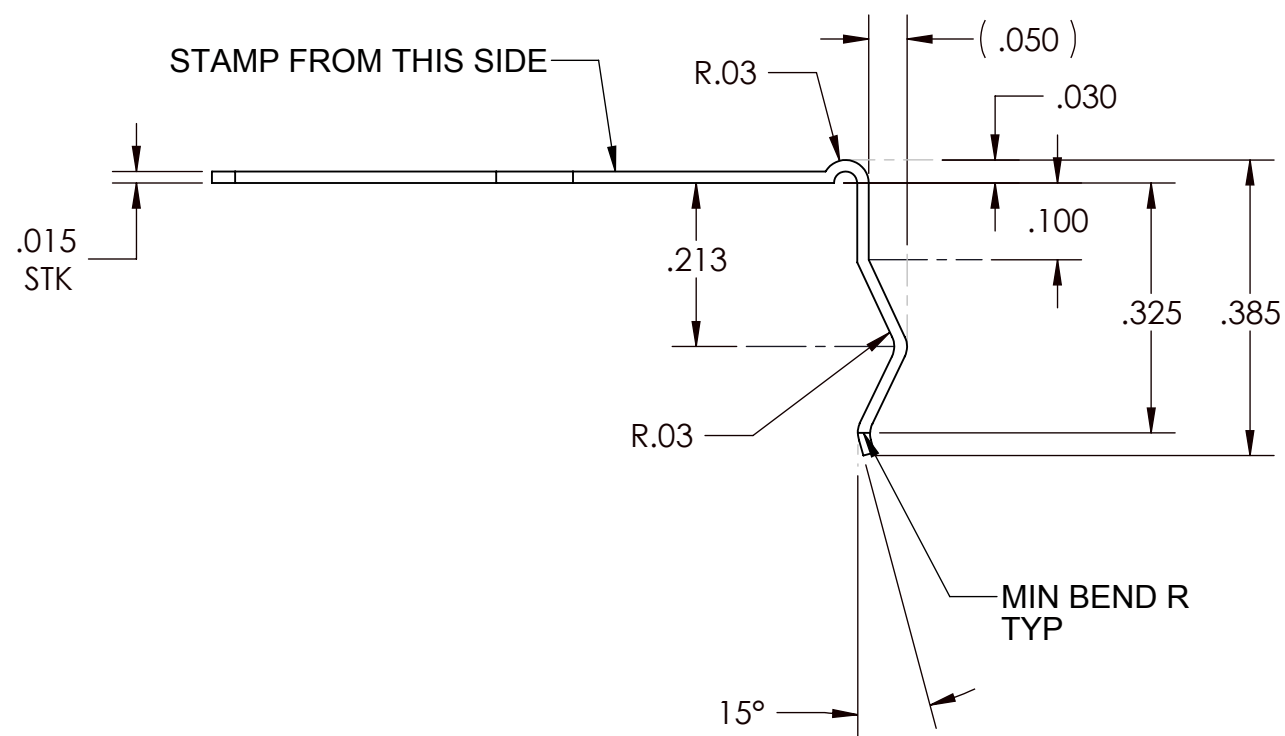
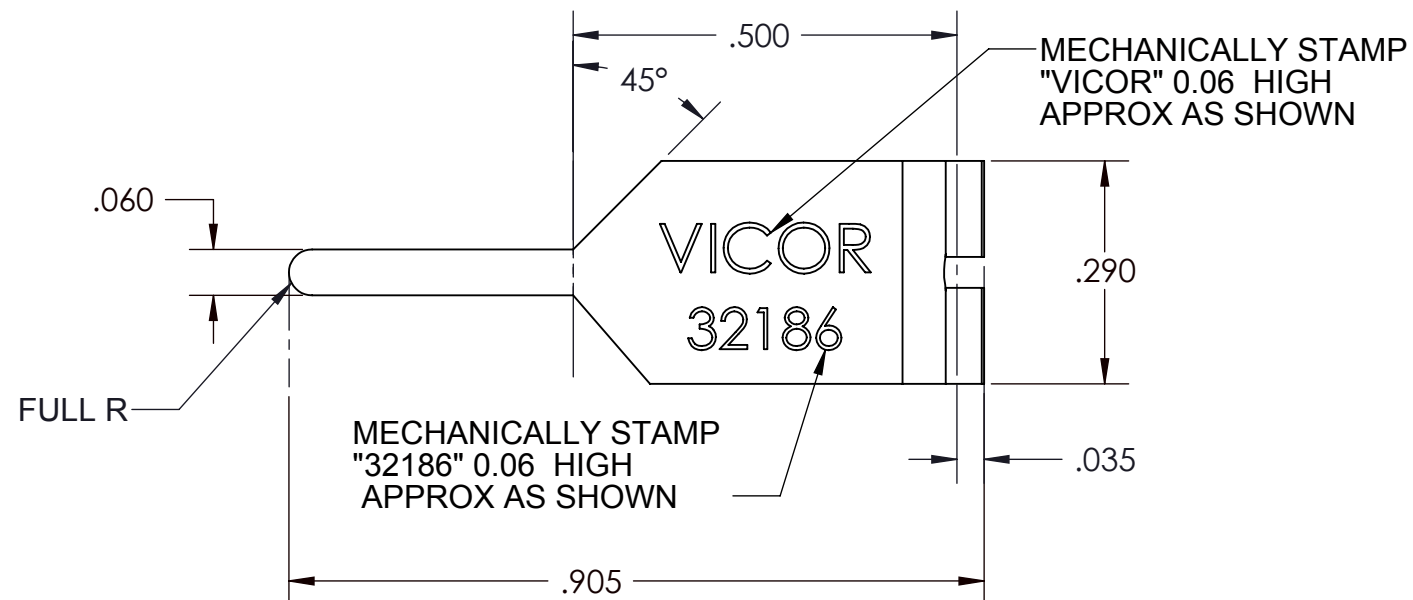

- NOTES:
1. MATERIAL: 260 BRASS, .015 THK, HALF HARD.
  2. FINISH: MATTE TIN OR FUSED MATTE TIN, 300-500 MICRO INCHES OVER 100-200 MICRO INCHES NICKEL.
  3. RoHS COMPLIANT, LEAD FREE PER CST-0001 LATEST REVISION.
  4. CORNERS SHOWN SHARP MAY BE .005 RADIUS.
  5. DIMENSIONS ARE INCHES ONLY.

DRAWN	DATE
P.E.IENI	12/15/05

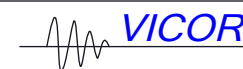

SWD

MATERIAL	UNLESS OTHERWISE SPECIFIED DIMENSIONS ARE INCH [MM] TOLERANCES ARE: DECIMALS      ANGLES X.XX [X.X] = ±0.01 [0.25]    ±1° X.XXX [X.XX] = ±0.005 [0.127]
FINISH	
THIRD ANGLE PROJECTION	
DO NOT SCALE DRAWING	

CLIP CROSSFLOW GROUNDING

SIZE	CAGE CODE	DWG NO	REV
<b>B</b>	<b>67131</b>	<b>32186</b>	<b>3</b>
SCALE 4 : 1		SHEET 1 OF 1	

8

7

6

5

4

3

2

1