

VICOR CONFIDENTIAL

THIS DOCUMENT AND THE DATA DISCLOSED HEREIN OR HERewith IS NOT TO BE REPRODUCED, USED, OR DISCLOSED IN WHOLE OR IN PART TO ANYONE WITHOUT PERMISSION OF VICOR CORP.

REV.	DESCRIPTION	DATE	APPROVED
1	RELEASED PER E060496	LEK	02/15/06
2	REVISED PER E060064	GCK	12/6/06
3	REVISED PER E080938	SA	5/6/08

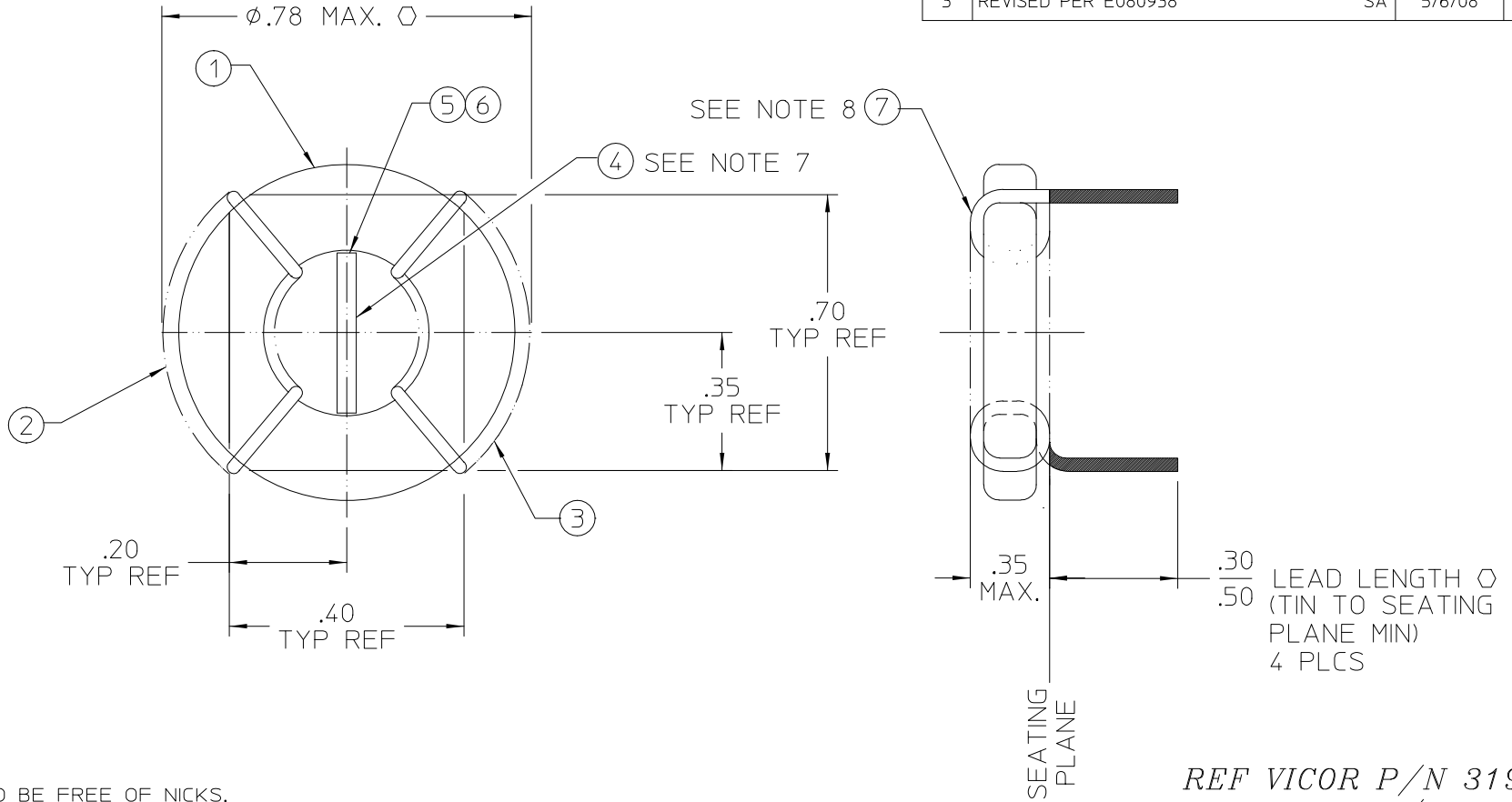

- NOTES:
- ASSEMBLY TO BE FREE OF NICKS.
 - WINDINGS TO BE EVENLY SPACED.
 - RoHS COMPLIANT, LEAD FREE PER CST-0001 LATEST REVISION, MAGNETICS SECTION.
 - GENERAL WORKMANSHIP STANDARDS FOR MAGNETIC COMPONENTS PER WS-0002.
 - OVERWINDS PERMISSIBLE.
 - LEADS CONFORMABLE TO LEAD DIMENSION.
 - BOND SPACER (ITEM 4) TO CORE (ITEM 1) USING ADHESIVE (ITEMS 5 & 6) OR EQUIVALENT-ONE END ONLY-AS SHOWN.
 - WIND FINISHED ASSY WITH TWO WRAPS OF TAPE, (ITEM 7).
 - Ø DENOTES CRITICAL CHARACTERISTIC FOR LOT INSPECTION.

REF VICOR P/N 31943
REF VICOR P/N 33884

DRAWN BY KNIGHT		DATE 02/15/06			
<small>UNLESS OTHERWISE SPECIFIED DIMENSIONS ARE IN INCHES- TOLERANCES ARE:</small> <small>FRACTIONS DECIMALS ANGLES</small> <small>±1/64 .XX= ±.01 ±1°</small> <small>.XXX=±.005</small>					
THIRD ANGLE PROJECTION 		SIZE B	FSCM NO. 67131	DWG NO 31947	REV 3
DO NOT SCALE DRAWING		SCALE NONE	SHEET 1 OF 1		