

VICOR CONFIDENTIAL  
 THIS DOCUMENT AND THE DATA DISCLOSED HEREIN OR  
 HEREWITH IS NOT TO BE REPRODUCED, USED OR  
 DISCLOSED IN WHOLE OR IN PART TO ANYONE WITHOUT  
 THE PERMISSION OF VICOR CORP.

REV.	DESCRIPTION	INTL	DATE	APVD
1	Released per ECO E141368	ESD	01/19/2015	RH

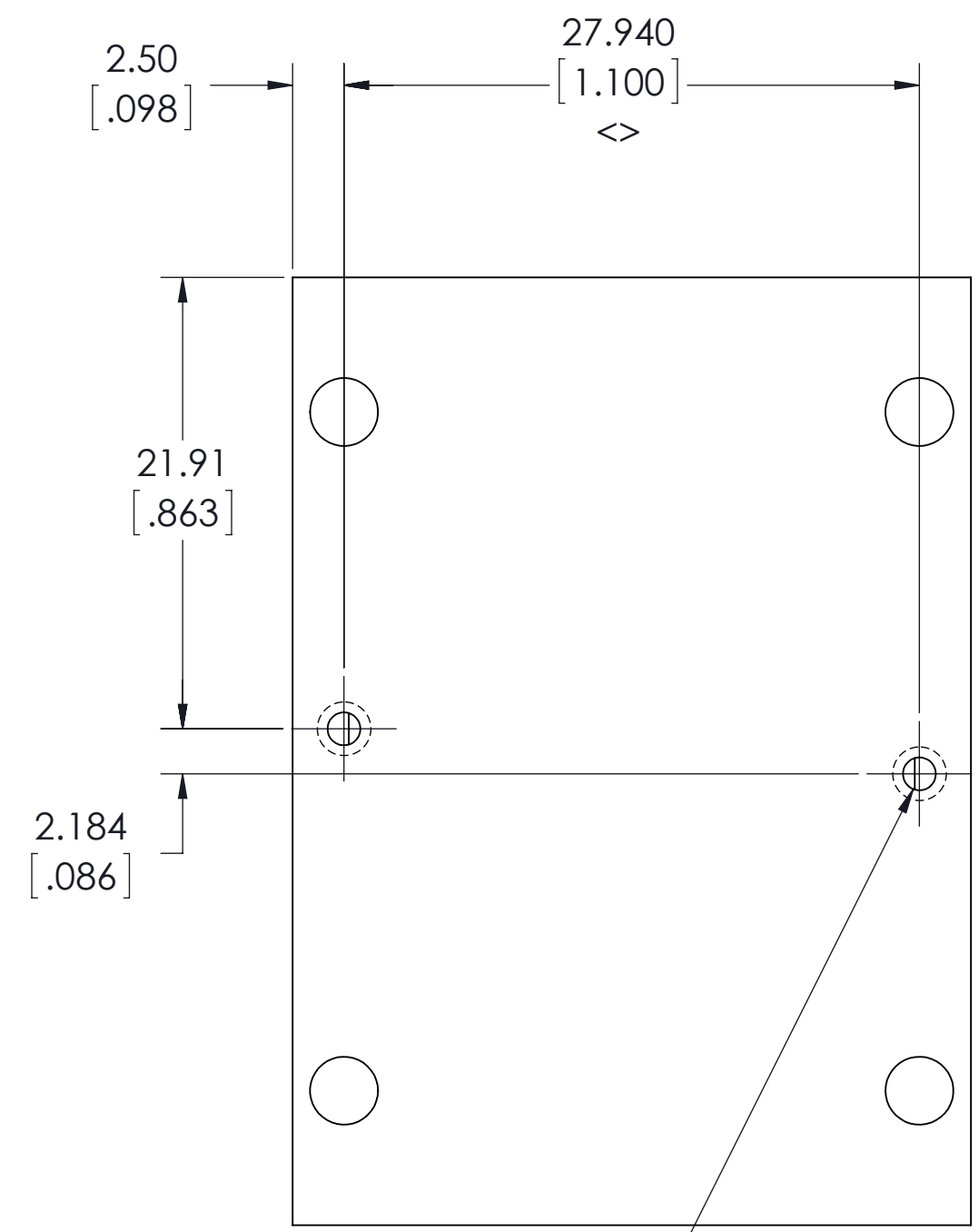

2X M2-.40 x 3.5MM DP TAP

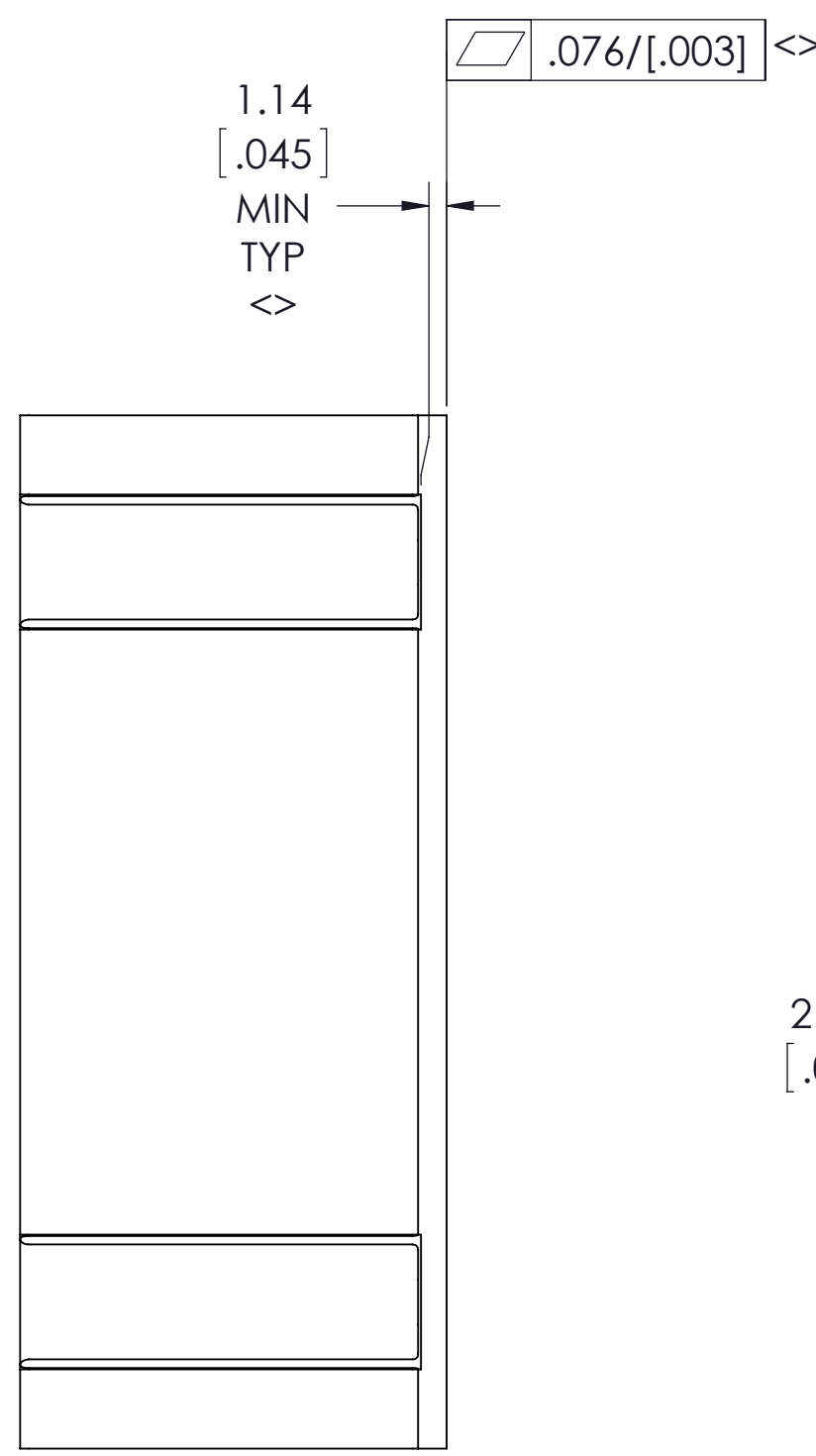
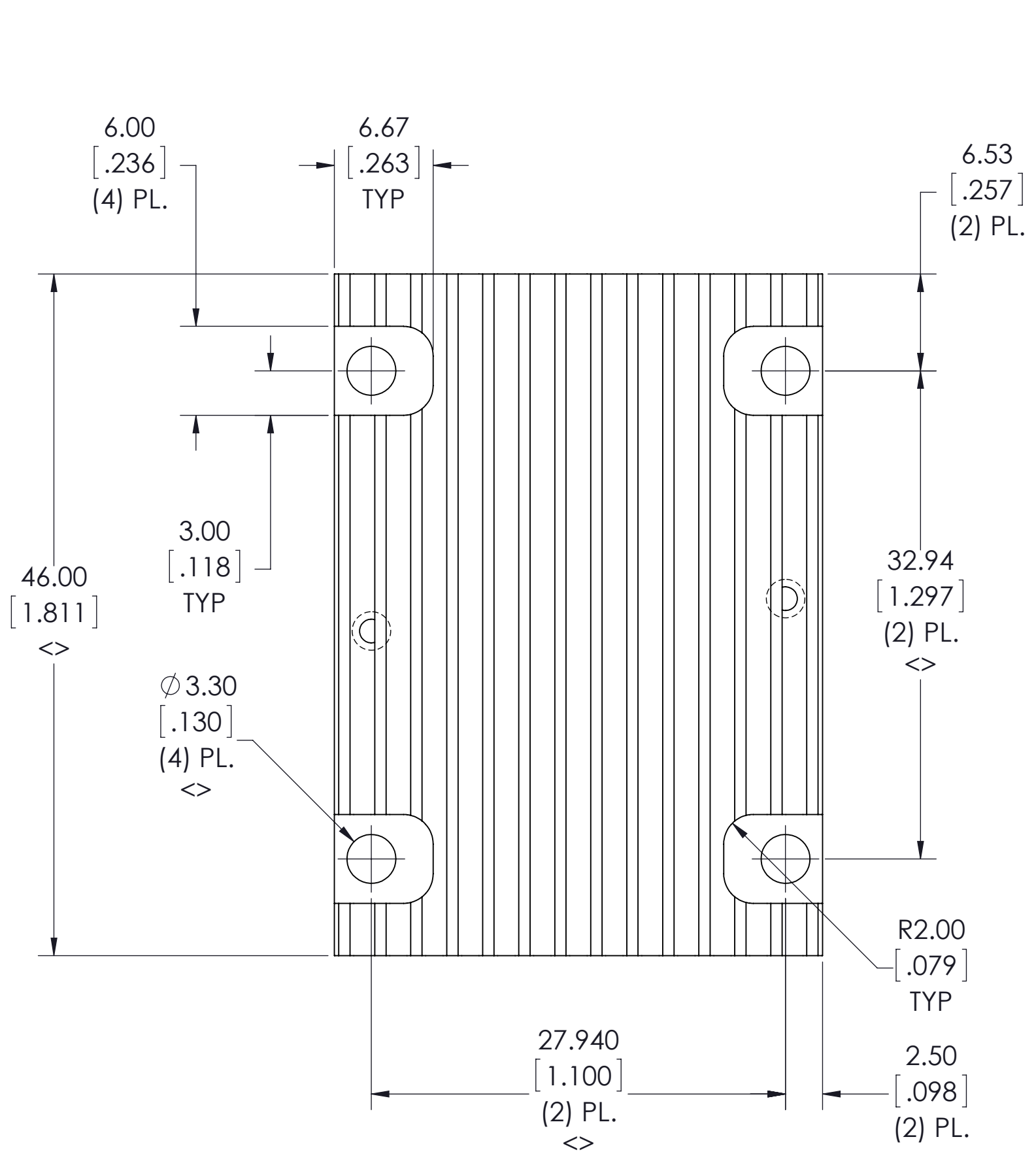
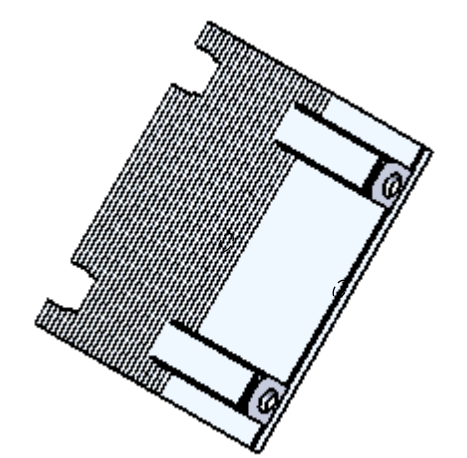

- NOTES:
- CLEAR FINISH, RoHS COMPLIANT PER CST-0001, LATEST REVISION PER A.) CHROMIUM FREE, OR B.) TRIVALENT CHROMIUM IN ACCORDANCE WITH MIL-DTL-5541, TYPE II, CLASS 1A OR 3. SEE CST-0003 FOR TYPES OF AVAILABLE FINISHES.
  - SEE 40429 FOR EXTRUSION PROFILE.
  - REMOVE ALL BURRS AND BREAK ALL SHARP EDGES.

DRAWN BY Robert Wasik	DATE 9/12/2013	<b>VICOR</b> SWD		
UNLESS OTHERWISE SPECIFIED DIMENSIONS ARE MM / (INCH) TOLERANCES ARE: DECIMALS      ANGLES X.XX [X.X] = ±0.25 [0.01] ±1° X.XXX [X.XX] = ±0.127 [0.005]		<b>HEATSINK, PUSH PIN, LF, 4623, 19MM</b>		
THIRD ANGLE PROJECTION 	SIZE <b>C</b>	CAGE CODE <b>67131</b>	DWG NO <b>40261</b>	REV <b>1</b>
DO NOT SCALE DRAWING	SCALE 3:1	SHEET 1 OF 1		