

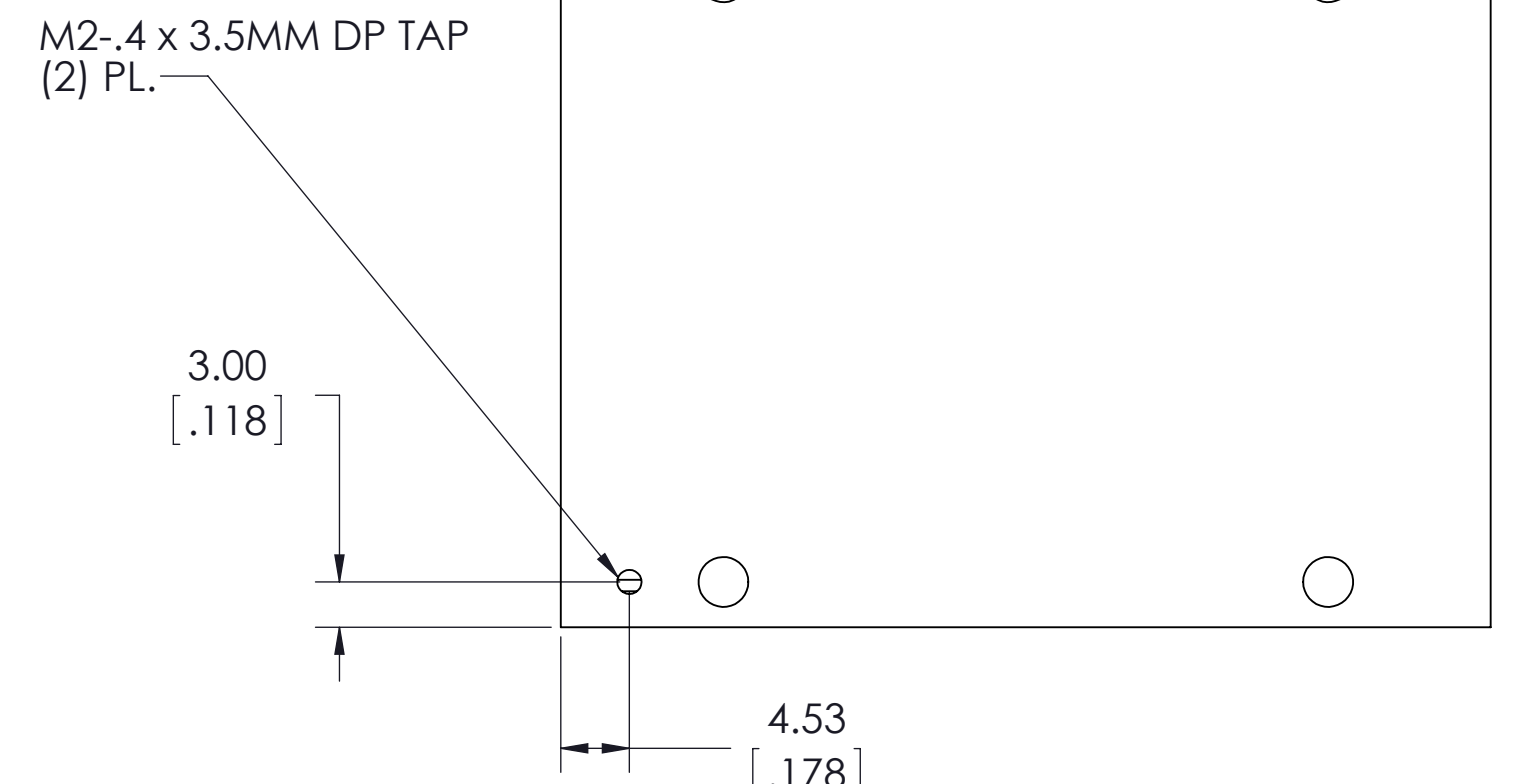

VICOR CONFIDENTIAL
 THIS DOCUMENT AND THE DATA DISCLOSED HEREIN OR
 HEREWITH IS NOT TO BE REPRODUCED, USED OR
 DISCLOSED IN WHOLE OR IN PART TO ANYONE WITHOUT
 THE PERMISSION OF VICOR CORP.

REV.	DESCRIPTION	INTL	DATE	APVD
1	Released per ECO E141368	ESD	1/19/15	RH

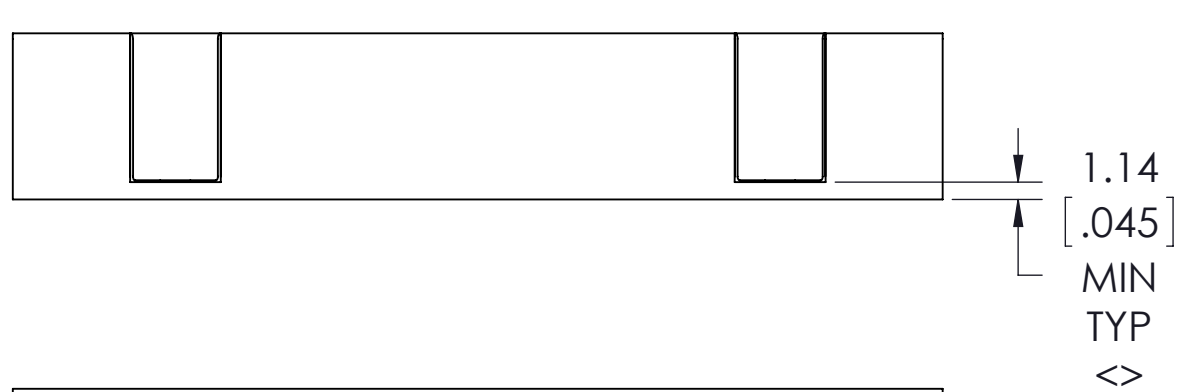
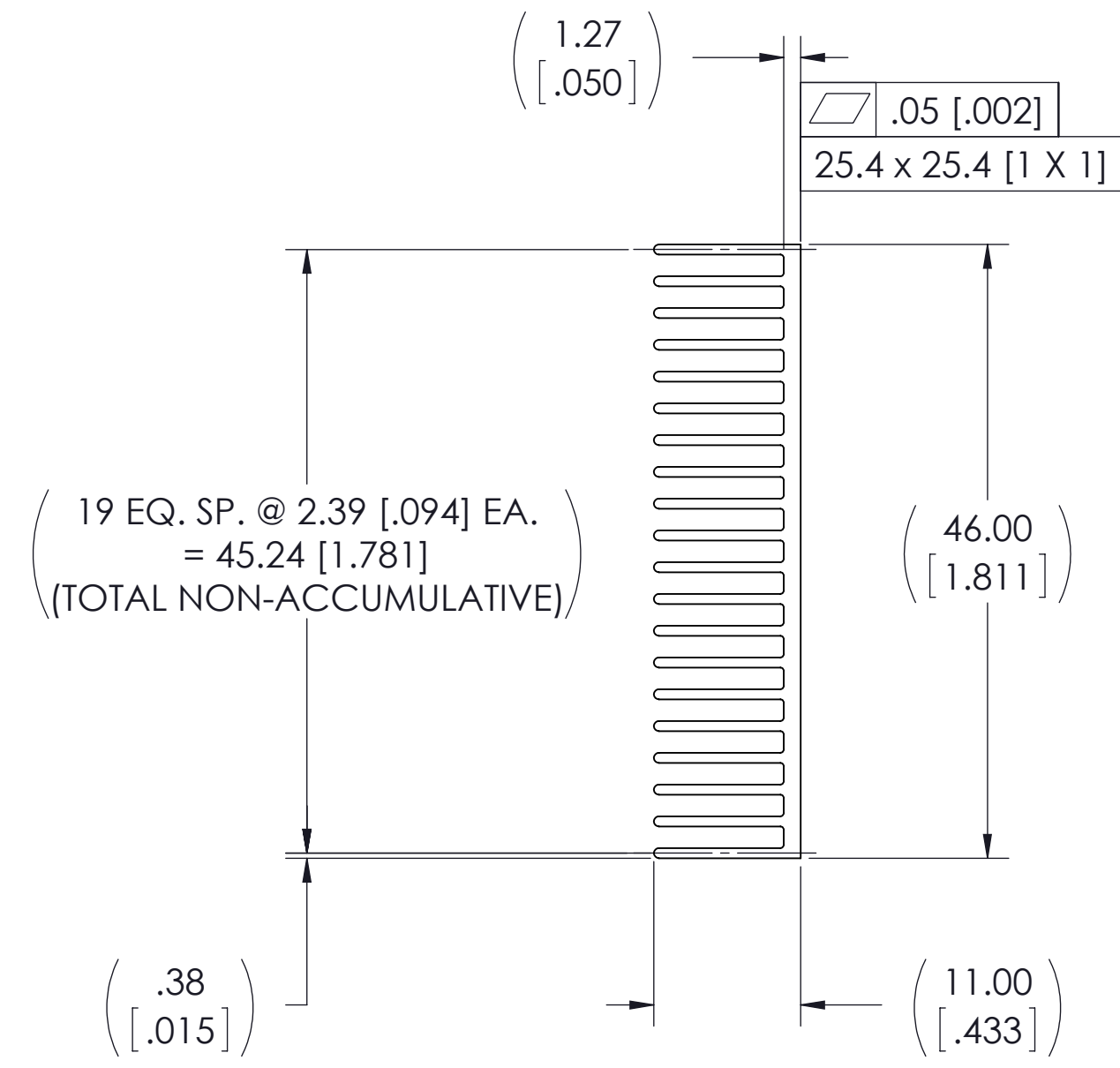
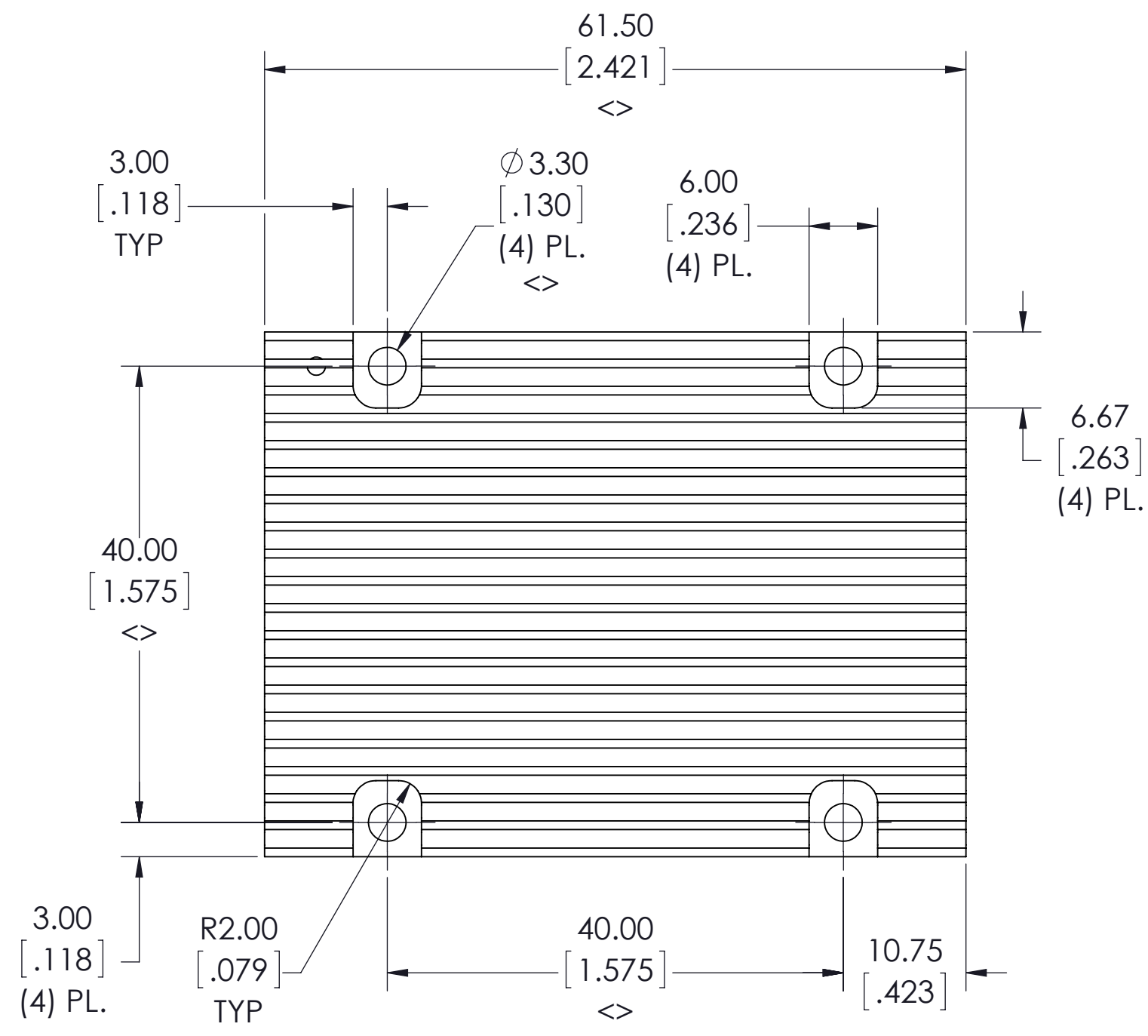
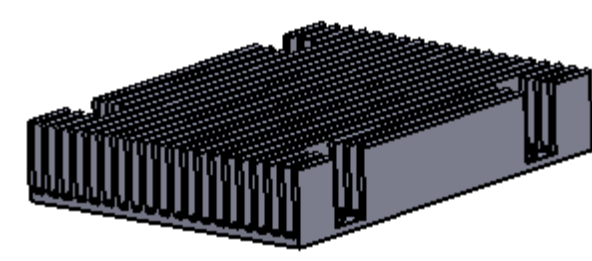

- NOTES:
1. MAKE FROM VICOR P/N 30827.
 2. FINISH: CLEAR FINISH, RoHS COMPLIANT PER CST-0001, LATEST REVISION PER
 A.) CHROMIUM FREE, OR
 B.) TRIVALENT CHROMIUM IN ACCORDANCE WITH MIL-DTL-5541, TYPE II, CLASS 1A OR 3. SEE CST-0003 FOR TYPES OF AVAILABLE FINISHES.
 3. REMOVE ALL BURRS AND SHARP EDGES.
 4. <> DENOTES CRITICAL CHARACTERISTIC FOR LOT INSPECTION.
 5. RoHS COMPLIANT, LEAD FREE PER CST-0001 LATEST REVISION.



DRAWN BY Robert Wasik	DATE 02/10/2014	VICOR SWD			
UNLESS OTHERWISE SPECIFIED DIMENSIONS ARE MM (INCH)		HEATSINK, PUSH PIN, LF, 2361, 11MM			
TOLERANCES ARE: DECIMALS ANGLES X.XX [X.X] = +0.25 [0.01] ±1° X.XXX [X.XXX] = ±0.127 [0.005]		SIZE C	CAGE CODE 67131	DWG NO 40032	REV 1
THIRD ANGLE PROJECTION 		SCALE 2:1		SHEET 1 OF 1	