

VICOR CONFIDENTIAL

THIS DOCUMENT AND THE DATA DISCLOSED HEREIN OR HEREWITH IS NOT TO BE REPRODUCED, USED, OR DISCLOSED IN WHOLE OR IN PART TO ANYONE WITHOUT PERMISSION OF VICOR CORP.

REV.	DESCRIPTION	DATE	APVD
1	DOCUMENT RELEASED PER E0912130	JS 07/31/09	REJH
2	DOCUMENT RELEASED PER E091826	JS 10/12/09	REJH

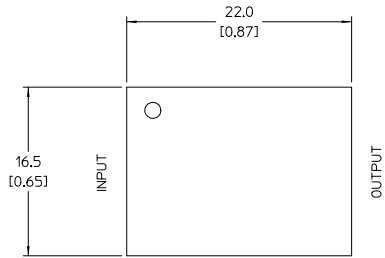

TOP VIEW (COMPONENT SIDE)

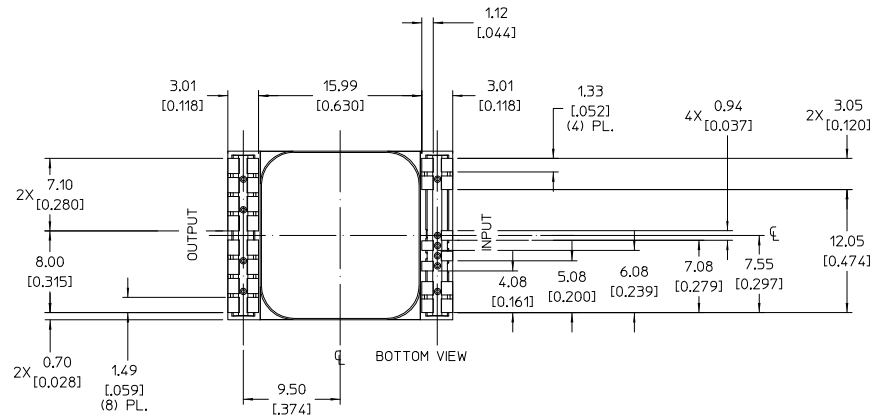
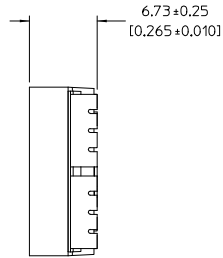

BOTTOM VIEW

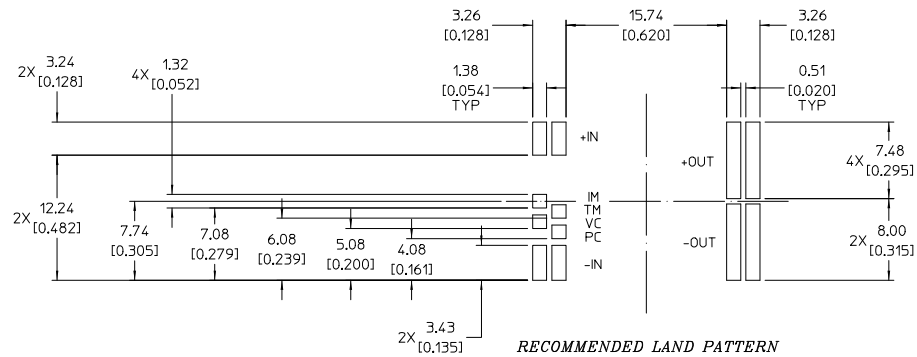
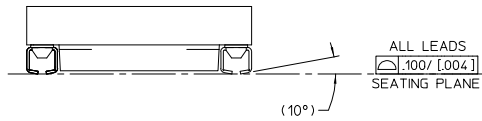

RECOMMENDED LAND PATTERN
(COMPONENT SIDE SHOWN)

NOTE:

1. RoHS COMPLIANT PER CST-0001 LATEST REVISION

DRAWN BY R.L. JIMENEZ CHECKED BY DATE 01/31/07 UNLESS OTHERWISE SPECIFIED DIMENSIONS ARE IN INCHES DECIMALS AND FRACTIONS UNLESS OTHERWISE SPECIFIED TOLERANCES ARE: FRACTIONS ± .005 DECIMALS ± .007 (MILS)	THIRD ANGLE PROJECTION 	SCALE 4:1	CAGE CODE 67131	DWG NO. 33490	REV. 2
J-LEAD 1/2 VTM PKG2 PRODUCTION OUTLINE		SHEET 1 OF 1			