

VICOR CONFIDENTIAL

THIS DOCUMENT AND THE DATA DISCLOSED HEREIN OR HEREWITH IS NOT TO BE REPRODUCED, USED, OR DISCLOSED IN WHOLE OR IN PART TO ANYONE WITHOUT PERMISSION OF VICOR CORP.

REV.	DESCRIPTION	DATE	APPROVED
1	RELEASED PER E063757	PEI 04/03/06	RLT
2	MODIFIED PER E063233	BW 08/02/06	RLT
3	MODIFIED PER E071489	JS 07/18/07	REJH
4	REVISED PER E071779	JS 08/15/07	REJH

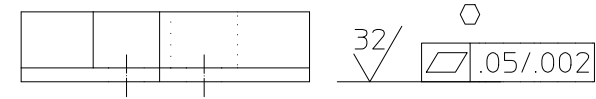
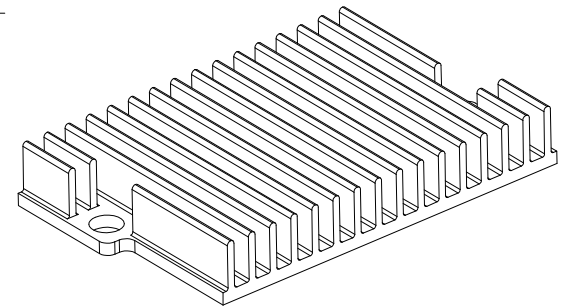
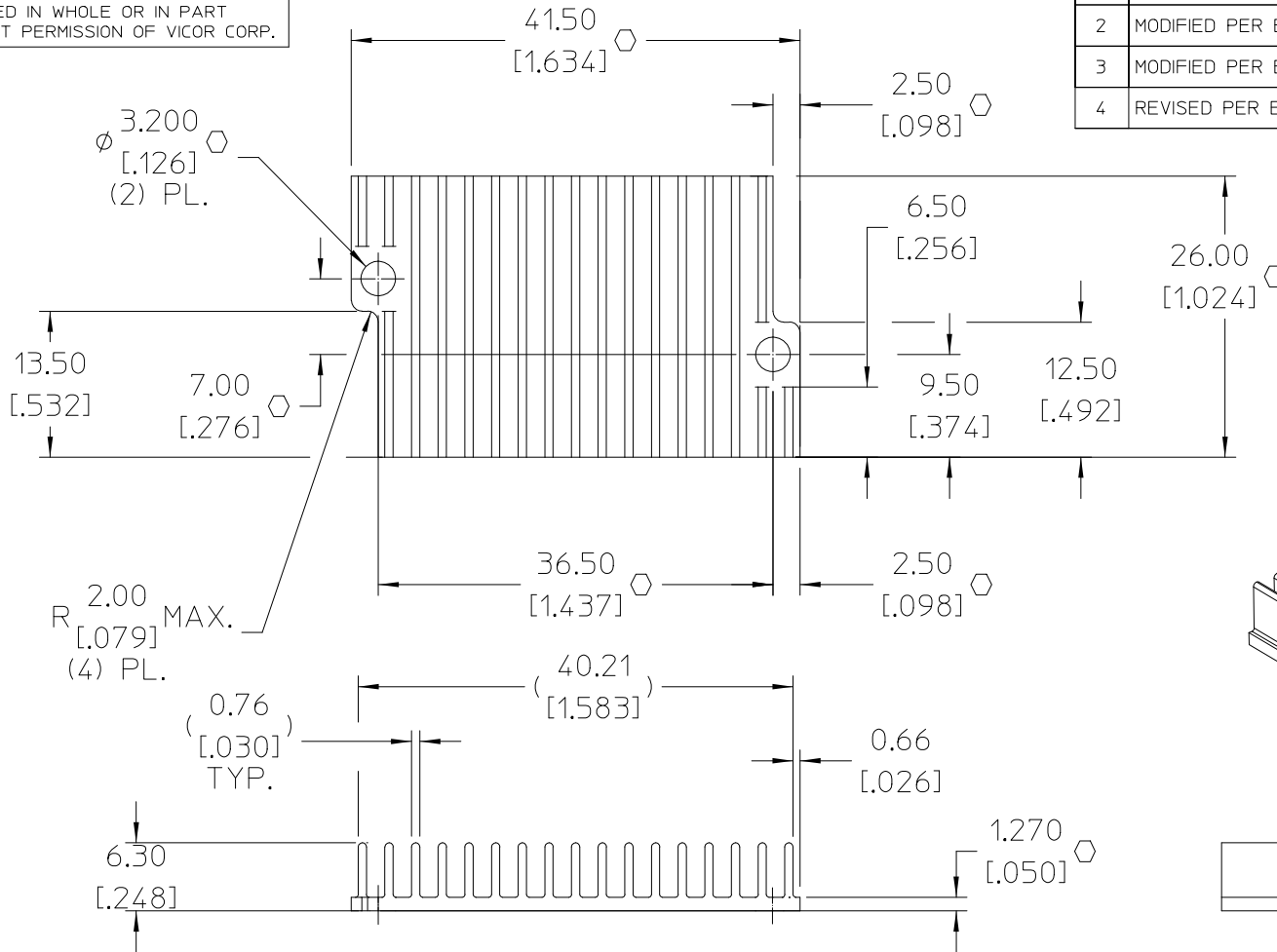

NOTES:

1. MAKE FROM VICOR PART NO. 32620.
2. FINISH: ANODIZE PER MIL-A-8625, TYPE II, CLASS 2, BLACK.
3. REMOVE ALL BURRS AND SHARP EDGES.
4. "O" DENOTES CRITICAL CHARACTERISTIC FOR LOT INSPECTION.
5. RoHS COMPLIANT, LEAD FREE PER CST-0001 LATEST REVISION.

DRAWN BY <i>D.CVINAR</i>		DATE 3/10/06			
<small>UNLESS OTHERWISE SPECIFIED DIMENSIONS ARE MM [INCH] TOLERANCES ARE:</small> <small>DECIMALS ANGLES</small> <small>.XX= ±0.25 [.01] ±1°</small> <small>.XXX= ±0.127 [.005]</small>					
THIRD ANGLE PROJECTION 		SIZE B	FSCM NO. 67131	DWG NO 32621	REV 4
DO NOT SCALE DRAWING		SCALE 2:1	SHEET 1 OF 1		