

REV.	DESCRIPTION	DATE	APVD
SEE SHEET 1			

CONFIGURATION 'B'
 COLDPLATE VERSION SHOWN
 SINGLE OUTPUT
 WITH PLUGMATES

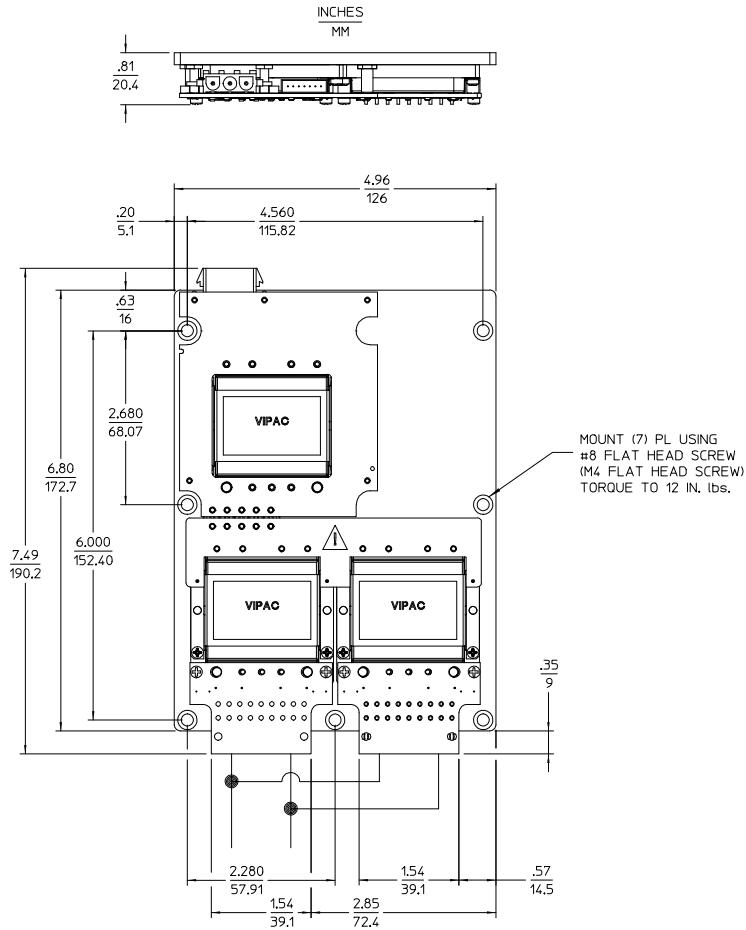

CUSTOMER MUST WIRE OUTPUTS OF CONVERTERS IN PARALLEL AS SHOWN REFER TO DATA SHEET FOR DETAILS.

TOLERANCES: $\frac{XX}{MM} = \frac{.02}{.5}$ $\frac{XXX}{MM} = \frac{.010}{.25}$

CONFIGURATION 'B'
 COLDPLATE VERSION SHOWN
 DUAL OUTPUT
 WITH PLUGMATES

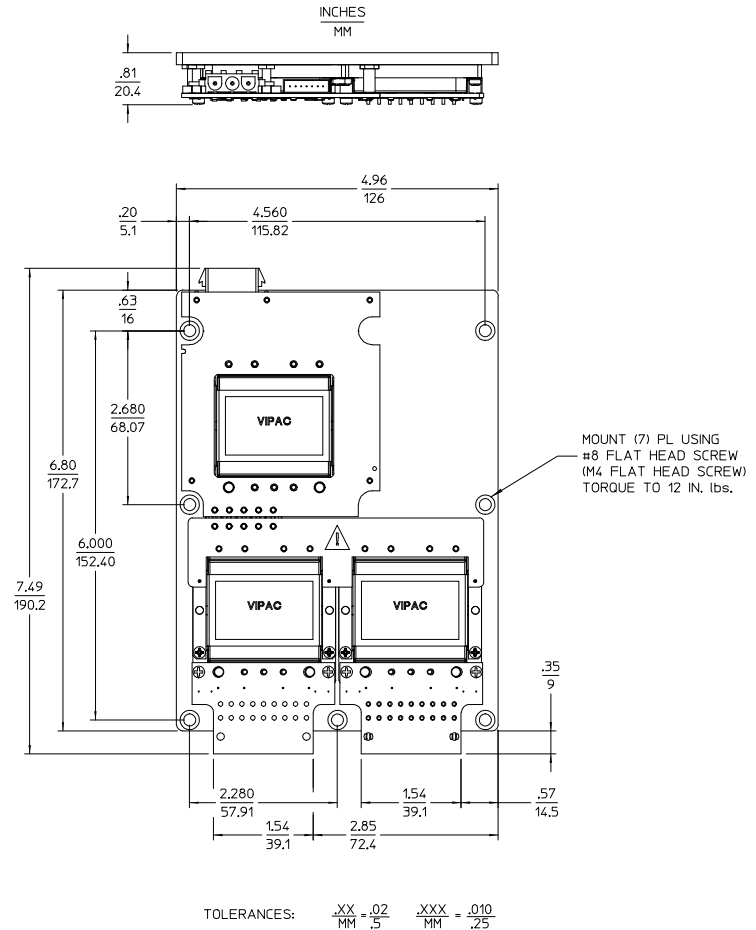

TOLERANCES: $\frac{XX}{MM} = \frac{.02}{.5}$ $\frac{XXX}{MM} = \frac{.010}{.25}$

DRAWN BY A. RIZMAR	DATE 12/12/00			
UNLESS OTHERWISE SPECIFIED DIMENSIONS ARE IN INCHES TOLERANCES ARE: FRACTIONS DECIMALS ANGLES .XX .XX .XX .XX .XX .XX				
THIRD ANGLE PROJECTION	SIZE D	P/SCH NO. 67131	DWG NO. 21318	REV 1
DO NOT SCALE DRAWING	SCALE 1:1	SHEET 2 OF 2		

REV.	DESCRIPTION	DATE	APVD
1	RELEASE PER E160775a	GCK 08/09/16	MTB

CONFIGURATION 'B'
 COLDPLATE VERSION SHOWN
 SINGLE OUTPUT
 WITH LUGMATES

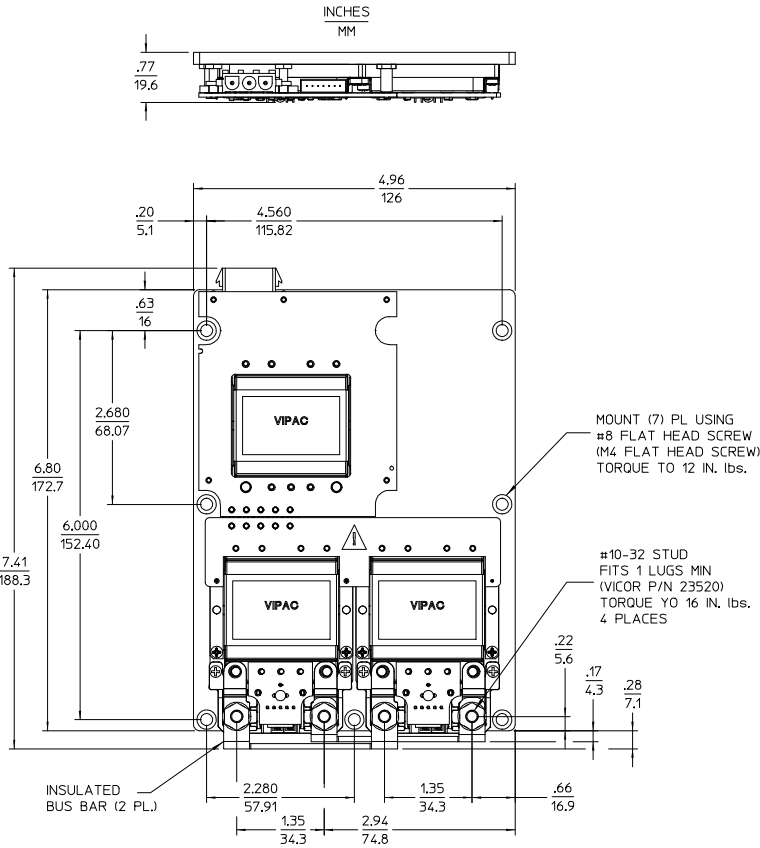

CONFIGURATION 'B'
 COLDPLATE VERSION SHOWN
 DUAL OUTPUT
 WITH LUGMATES

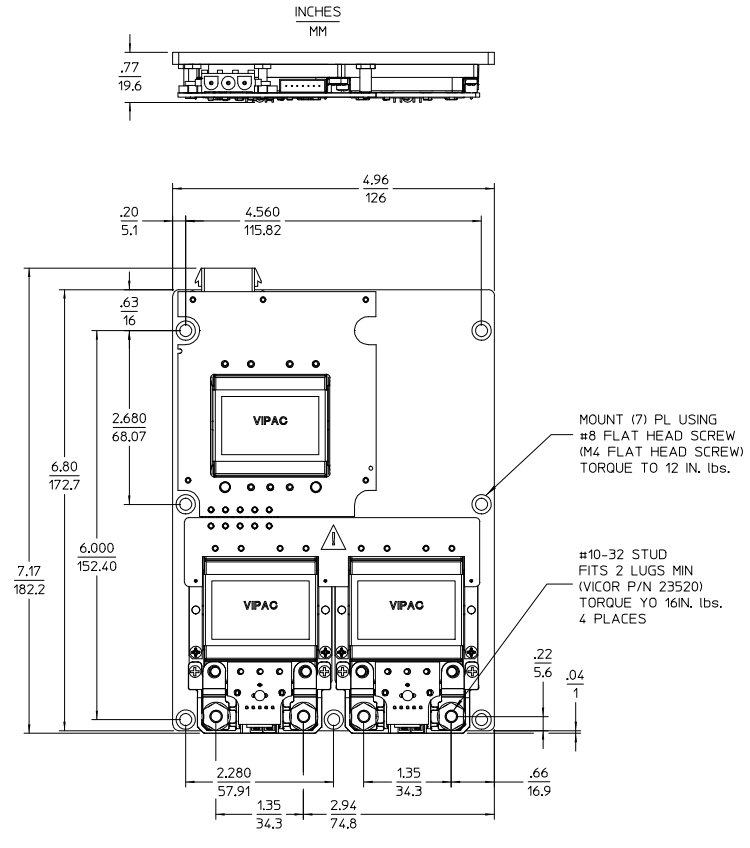

DRAWN BY A. RIZMAR	DATE 12/12/00			
UNLESS OTHERWISE SPECIFIED DIMENSIONS ARE IN INCHES TOLERANCES ARE: FRACTIONS DECIMALS ANGLES .XX .01 .10 .10 .XXX .005 .005 .10				
THIRD ANGLE PROJECTION	SIZE D	PSCM NO. 67131	DWG NO. 21318	REV 1
DO NOT SCALE DRAWING	SCALE 1:1	SHEET 1 OF 2		