

VICOR CONFIDENTIAL

THIS DOCUMENT AND THE DATA DISCLOSED HEREIN OR HEREWITH IS NOT TO BE REPRODUCED, USED OR DISCLOSED IN WHOLE OR IN PART TO ANYONE WITHOUT THE PERMISSION OF VICOR CORP.

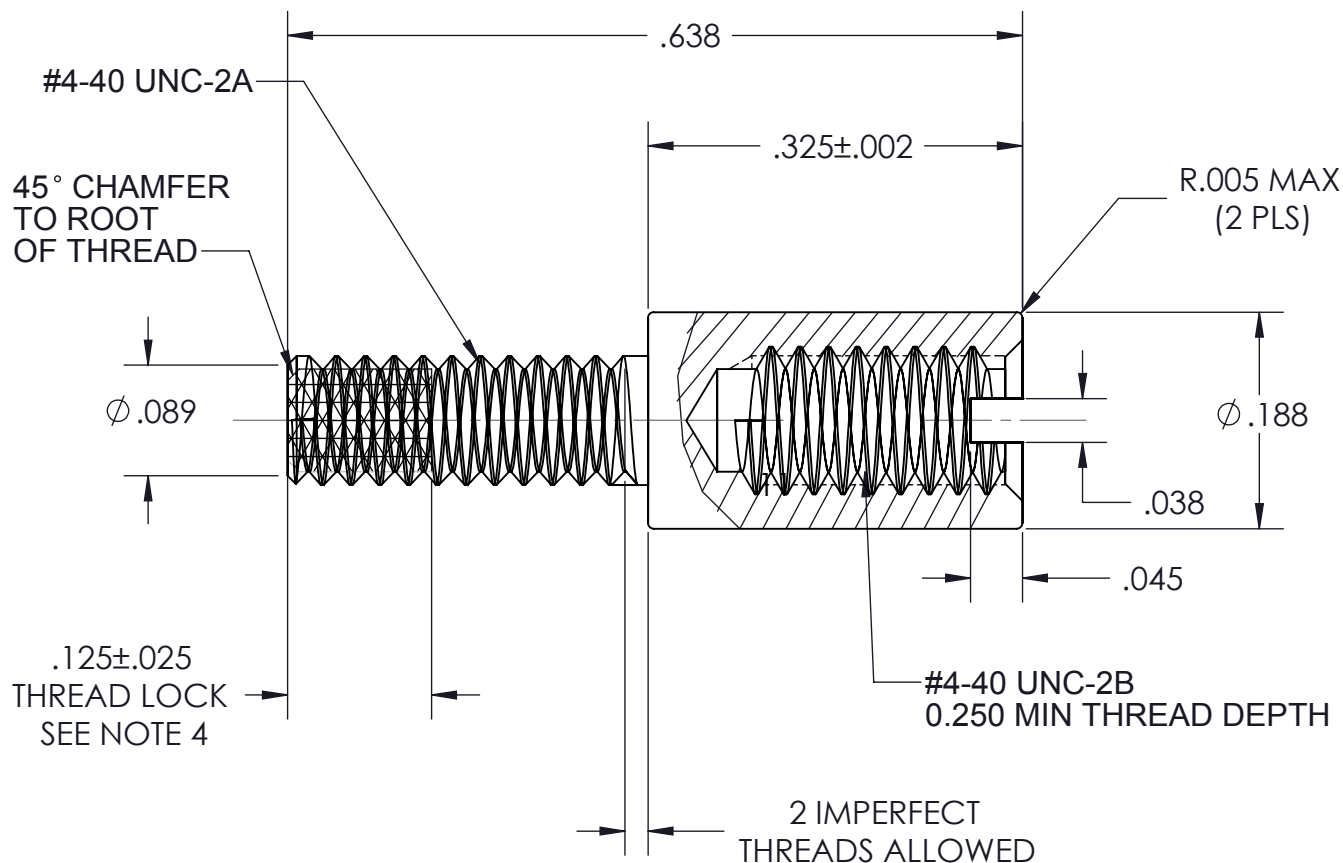

REV.	DESCRIPTION	DATE	APPROVED
1	RELEASE PER E9830074	PEI 11/13/98	JMR
2	REVISED PER E0030403	PEI 12/15/00	JMR
3	REVISED PER E100944	KUK 07/22/10	DCS
4	REVISED PER E120737	REJH 08/13/12	KUK
5	REVISED PER E120756	KUK 08/20/12	REJH

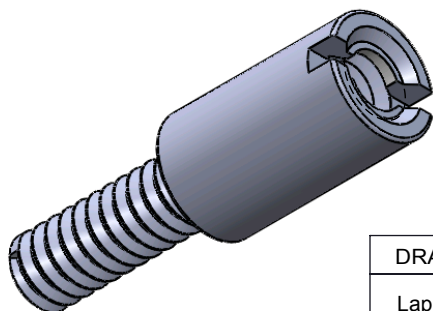

NOTES:

1. MATERIAL: 300 SERIES STAINLESS STEEL PER AISI.
2. FINISH: CLEAR PASSIVATE PER QQ-P-35B, TYPE II.
3. REMOVE ALL BURRS AND SHARP EDGES.
4. MACHINE APPLY LOCTITE DRI-LOC 204 OR EQUIVALENT TO THREADS AS SHOWN.
5. KIT P/N 18152
6. BAG P/N 19128
7. DIMENSIONS ARE INCHES ONLY.
8. RoHS COMPLIANT PER CST-0001 LATEST REVISION.



DRAWN BY	DATE	 VICOR		SWD
Lap Nguyen	11/24/1997	STANDOFF, 0.325 LG MALE-FEMALE (.638)		
UNLESS OTHERWISE SPECIFIED DIMENSIONS ARE : INCH / [MM]		SIZE	CAGE CODE	DWG NO
TOLERANCES ARE: DECIMALS X.XX [X.X] = ±0.01 [0.25] X.XXX [X.XX] = ±0.005 [0.127]		A	67131	18118
THIRD ANGLE PROJECTION 		SCALE 6:1		REV 5
DO NOT SCALE DRAWING				SHEET 1 OF 1