

8

7

6

5

4

3

2

1

VICOR CONFIDENTIAL

THIS DOCUMENT AND THE DATA DISCLOSED HEREIN OR HEREWITH IS NOT TO BE REPRODUCED, USED OR DISCLOSED IN WHOLE OR IN PART TO ANYONE WITHOUT THE PERMISSION OF VICOR CORP.

REVISIONS

REV	DESCRIPTION		DATE	APPROVED
1	RELEASED PER E050349	PEI	11/15/05	ECF
2	REVISED PER E100622	GCK	04/28/10	REJH
3	REVISED PER E100872	KUK	06/30/10	DCS

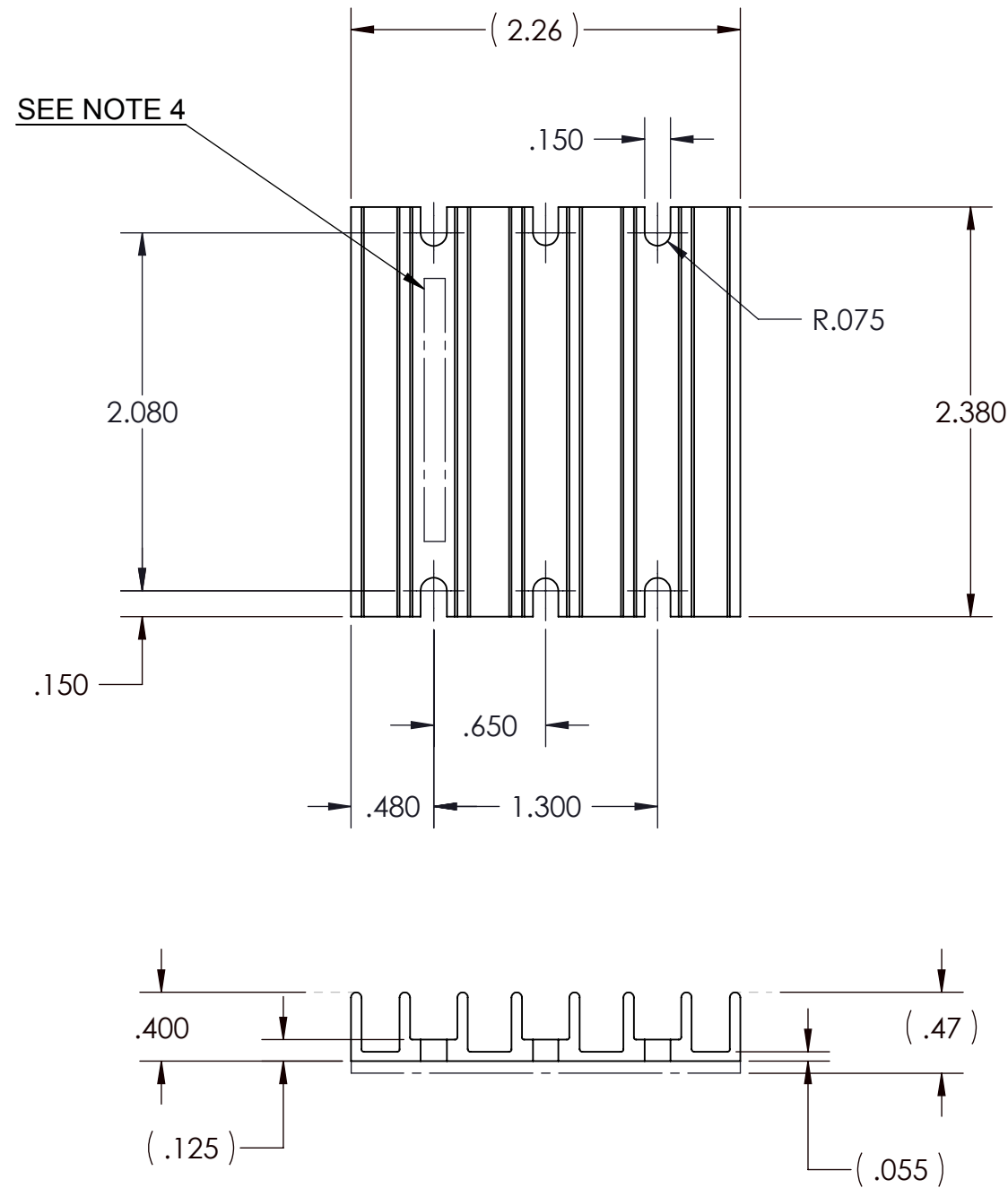

SEE NOTE 4

R.075

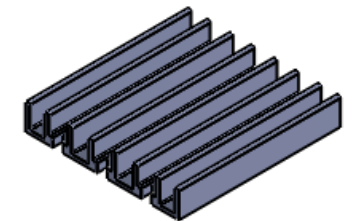

NOTES

- 1.MATERIAL: EXTRUSION SEE SHEET 2 OF 2
- 2.CLEAR FINISH, RoHS COMPLIANT, CHROMIUM FREE PER CST-0001 LATEST REVISION.
- 3.REMOVE ALL LOOSE BURRS.
- 4.MECHANICALLY STAMP PART NUMBER AND REVISION IN AREA SHOWN.
5. ○ DENOTES CRITICAL CHARACTERISTIC FOR LOT INSPECTION.
6. DIMENSIONS ARE INCHES ONLY.

DRAWN	DATE			
P.E.IENI	5/24/05			
MATERIAL	UNLESS OTHERWISE SPECIFIED DIMENSIONS ARE INCH [MM] TOLERANCES ARE: DECIMALS ANGLES X.XX [X.X] = ±0.01 [0.25] ±1° X.XXX [X.XX] = ±0.005 [0.127]	HEATSINK X FLOW 0.40 HT SLOTTED MINI MOD		
FINISH	THIRD ANGLE PROJECTION DO NOT SCALE DRAWING			
SIZE	CAGE CODE	DWG NO	REV	
B	67131	30140	3	
SCALE 1 : 1		SHEET 1 OF 2		

8

7

6

5

4

3

2

1

8

7

6

5

4

3

2

1

VICOR CONFIDENTIAL

THIS DOCUMENT AND THE DATA DISCLOSED HEREIN OR HEREWITH IS NOT TO BE REPRODUCED, USED OR DISCLOSED IN WHOLE OR IN PART TO ANYONE WITHOUT THE PERMISSION OF VICOR CORP.

REVISIONS

REV	DESCRIPTION	DATE	APPROVED
	SEE SHEET 1 OF 2		

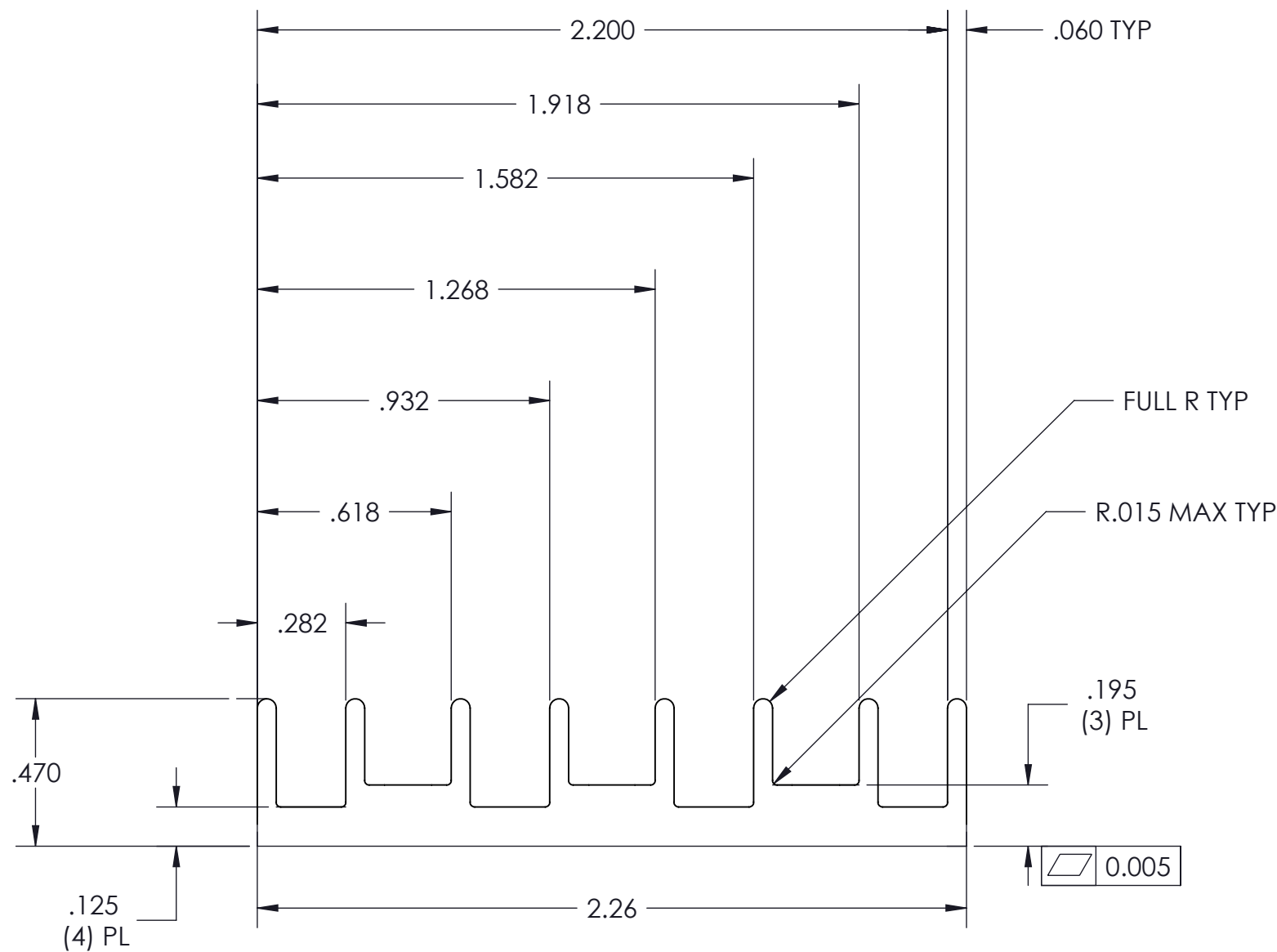

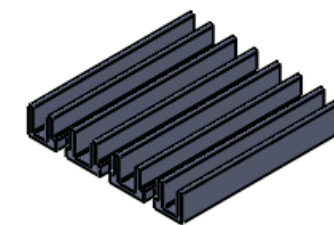

PROFILE COMMON FOR
30140



NOTES:

1. MATERIAL ALUMINIUM: 6063-T5
2. BREAK ALL EDGES AND SHARP CORNERS.
3. RoHS COMPLIANT PER CST-0001 LATEST REVISION.
4. DIMENSIONS ARE INCHES ONLY.

DRAWN	DATE			SWD	
G.C.KEAY	04/28/10				
MATERIAL	UNLESS OTHERWISE SPECIFIED DIMENSIONS ARE INCH [MM] TOLERANCES ARE: DECIMALS ANGLES X.XX [X.X] = ±0.01 [0.25] ±1° X.XXX [X.XX] = ±0.005 [0.127]		HEATSINK X FLOW 0.40 HT SLOTTED MINI MOD EXTRUSION		
FINISH	THIRD ANGLE PROJECTION	SIZE			CAGE CODE
	 DO NOT SCALE DRAWING	B	67131	30140	3
		SCALE 2 : 1	SHEET 2 OF 2		

8

7

6

5

4

3

2

1

F
E
D
C
B
A