

THIS DOCUMENT AND THE DATA DISCLOSED HEREIN OR HEREWITH IS NOT TO BE REPRODUCED, USED, OR DISCLOSED IN WHOLE OR IN PART TO ANYONE WITHOUT PERMISSION OF VICOR CORP.

REV.	DESCRIPTION	DATE	APVD
#1	DRAWN FOR DEVELOPMENT	AK 12/11/00	TR
#2	REVSD PER MRKUP	AK 07/31/01	GCK
#3	REVSD PER MRKUP	AK 12/05/01	GCK
#4	ADDED SHEET 2	AK 08/09/02	CFH
#5	REVSD PER MRKUP	AK 05/11/05	GCK

CONFIGURATION 'E'
 COLDPLATE VERSION SHOWN
 SINGLE OUTPUT
 WITH LUGMATE

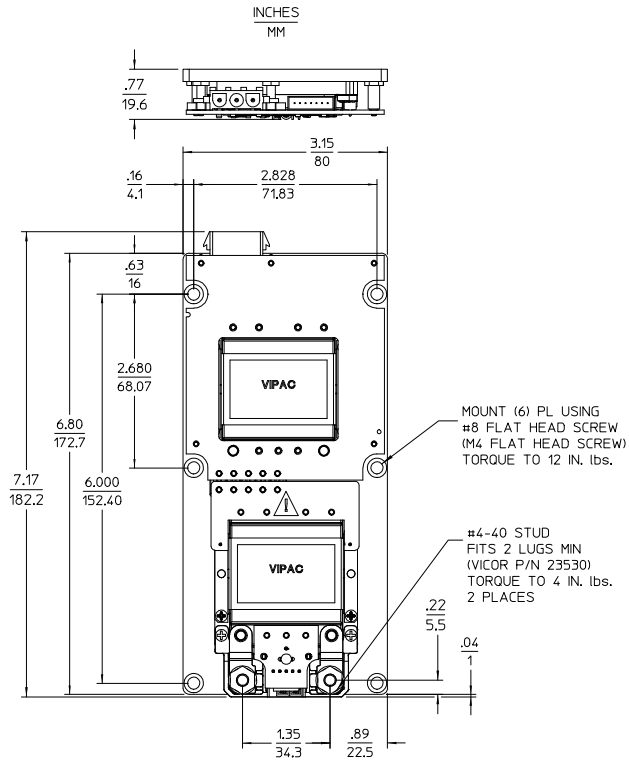

CONFIGURATION 'E'
 COLDPLATE VERSION SHOWN
 SINGLE OUTPUT
 WITH PLUGMATE

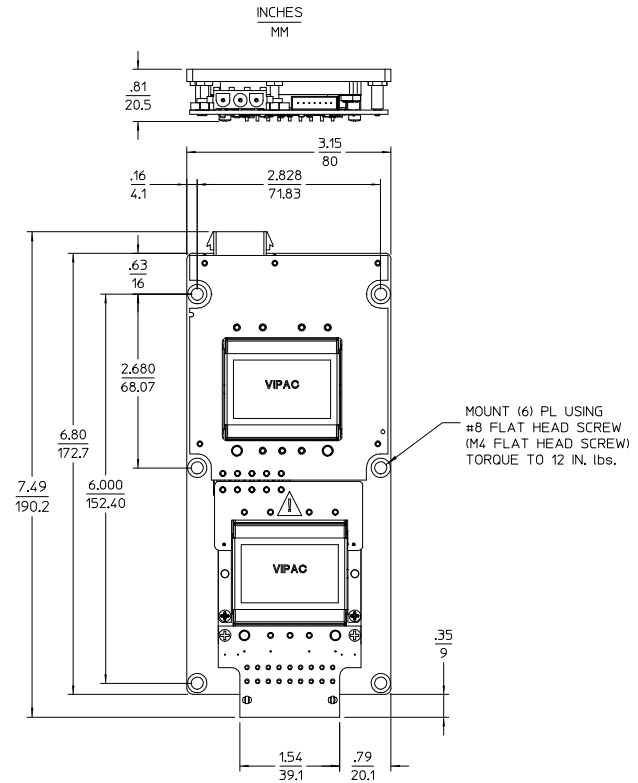

DRAWN BY A. ARDMAN	DATE 12/11/00	<p>OUTLINE DRAWING VIPAC CONFIG 'E' (DC)</p>		
<small>UNLESS OTHERWISE SPECIFIED DIMENSIONS ARE IN INCHES TOLERANCES ARE: FRACTIONS DECIMALS ANGLES +ve/- .01 .01 .1°</small>				
THIRD ANGLE PROJECTION	SIZE D	PSCH NO. 67131	DWG NO. 21321	REV #5
DO NOT SCALE DRAWING	SCALE 1:1	SHEET 1 OF 1		