

THIS DOCUMENT AND THE DATA DISCLOSED HEREIN OR HEREWITH IS NOT TO BE REPRODUCED, USED, OR DISCLOSED IN WHOLE OR IN PART TO ANYONE WITHOUT PERMISSION OF VICOR CORP.

REV.	DESCRIPTION	DATE	APVD
SEE SHEET 1			

CONFIGURATION 'C'
COLDPLATE VERSION SHOWN
SINGLE OUTPUT
WITH PLUGMATES

INCHES
MM

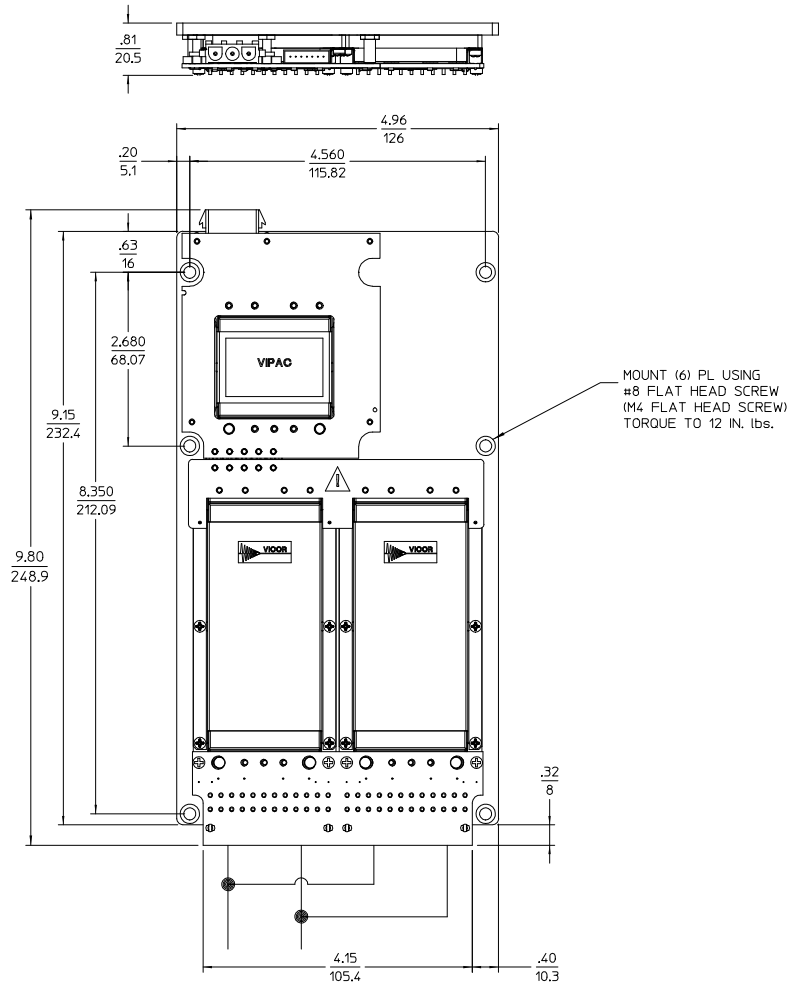

CUSTOMER MUST WIRE OUTPUTS OF CONVERTERS IN PARALLEL AS SHOWN. REFER TO DATA SHEET FOR DETAILS.

TOLERANCES: $\frac{.XX}{MM} = \frac{.02}{.5}$ $\frac{.XXX}{MM} = \frac{.010}{.25}$

CONFIGURATION 'C'
COLDPLATE VERSION SHOWN
DUAL OUTPUT
WITH PLUGMATES

INCHES
MM

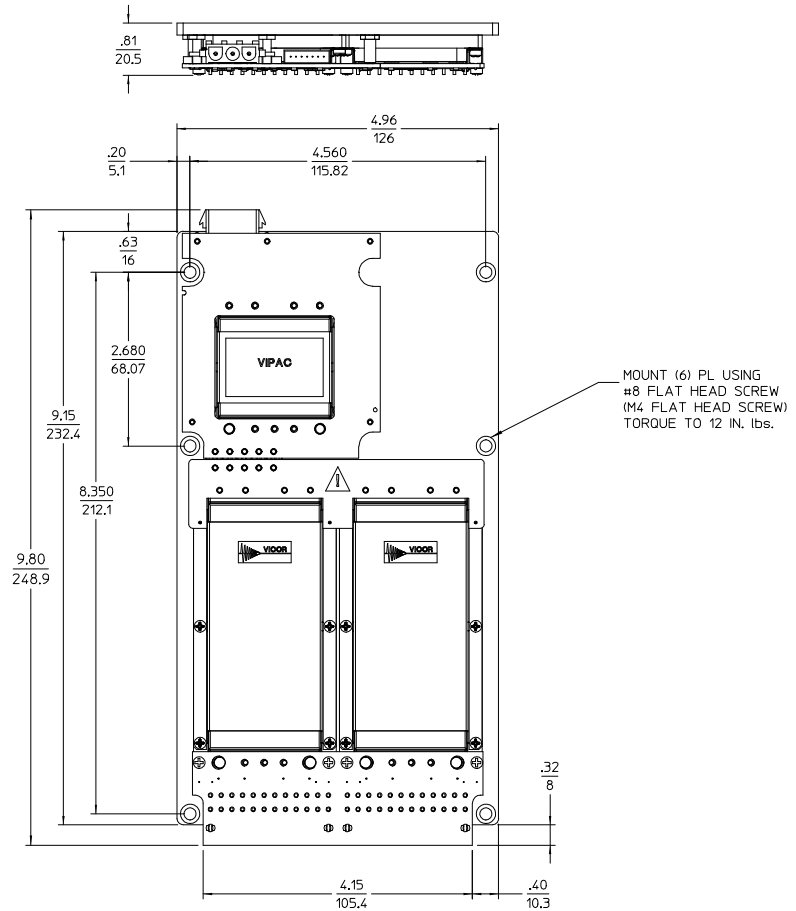

TOLERANCES: $\frac{.XX}{MM} = \frac{.02}{.5}$ $\frac{.XXX}{MM} = \frac{.010}{.25}$

DRAWN BY A. KIDMAR	DATE 12/11/00				
<small>UNLESS OTHERWISE SPECIFIED DIMENSIONS ARE IN INCHES TOLERANCES ARE: FRACTIONS DECIMALS ANGLES +.000 - .001 +.000 +.000</small>					
THIRD ANGLE PROJECTION		SIZE D	PSCH NO. 67131	DWG NO. 21319	REV #6
DO NOT SCALE DRAWING		SCALE 1:1	SHEET 2		OF 2

THIS DOCUMENT AND THE DATA DISCLOSED HEREIN OR HEREWITH IS NOT TO BE REPRODUCED, USED, OR DISCLOSED IN WHOLE OR IN PART TO ANYONE WITHOUT PERMISSION OF VICOR CORP.

CONFIGURATION 'C'
COLDPLATE VERSION SHOWN
SINGLE OUTPUT
WITH LUGMATES

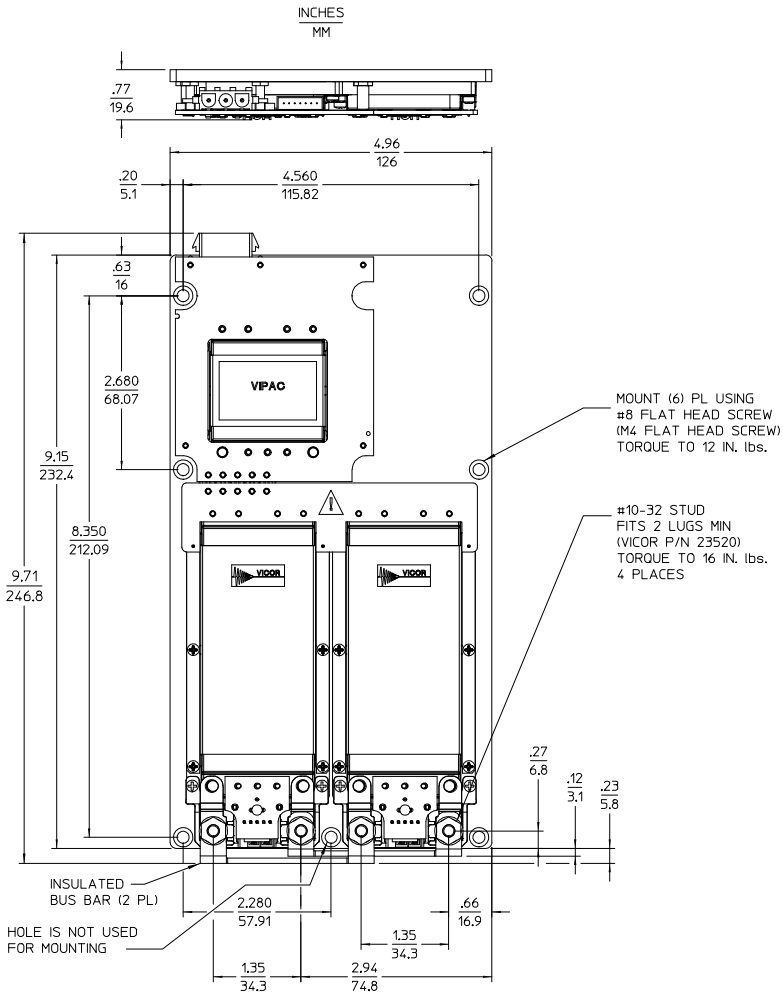

CONFIGURATION 'C'
COLDPLATE VERSION SHOWN
DUAL OUTPUT
WITH LUGMATES

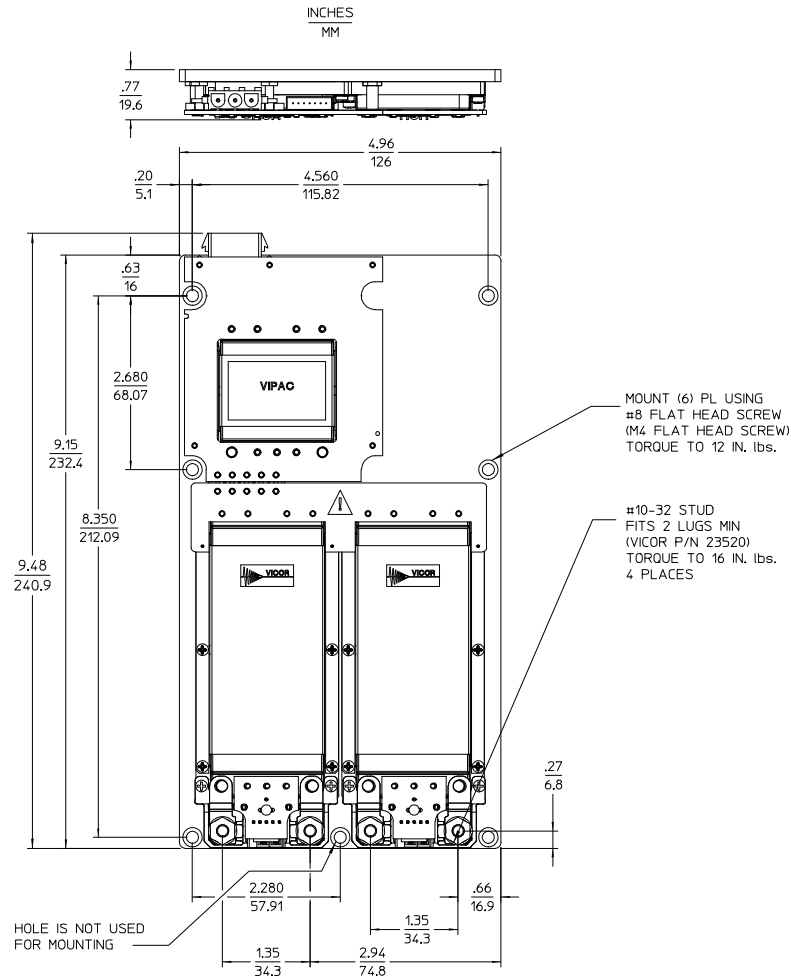

REV.	DESCRIPTION	DATE	APVD
#1	DRAWN FOR DEVELOPMENT	AK 12/11/00	TR
#2	REVSD PER MRKUP	AK 07/31/01	GCK
#3	REVSD PER MRKUP	AK 12/04/01	GCK
#4	ADDED SHEET 2 AND 3	AK 08/07/02	CFH
#5	ADDED WIRE OUTPUTS	DPK 3/12/03	AK
#6	REVSD PER MRKUP	AK 5/24/05	GCK

DRAWN BY A. RIZMAR UNLESS OTHERWISE SPECIFIED DIMENSIONS ARE IN INCHES TOLERANCES ARE: FRACTIONS DECIMALS ANGLES .XX .01 .1° .XXX .005 .01° .XXX .005 .01°	DATE 12/11/00	
THRD ANGLE PROJECTION DO NOT SCALE DRAWING		SIZE D 67131
SCALE 1:1		DWG NO 21319
SHEET 1 OF 2		REV #6

OUTLINE DRAWING
 VIPAC CONFIG 'C' (DC)