

VICOR CONFIDENTIAL
 THIS DOCUMENT AND THE DATA DISCLOSED HEREIN OR
 HEREWITH IS NOT TO BE REPRODUCED, USED OR
 DISCLOSED IN WHOLE OR IN PART TO ANYONE WITHOUT
 THE PERMISSION OF VICOR CORP.

REVISIONS				
REV	DESCRIPTION	DATE	APPROVED	
1	RELEASED PER E050350	LEK	11/16/05	EF
2	REVISED PER E091652	JS	09/11/09	REJH
3	REDRAWN PER E100871	DCS	6/28/10	KUK

#4-40 UNC-2B COLD FORM TAP
 .140 DP MIN. FROM FAR SIDE
 DO NOT BREAK THRU
 (6) PL.

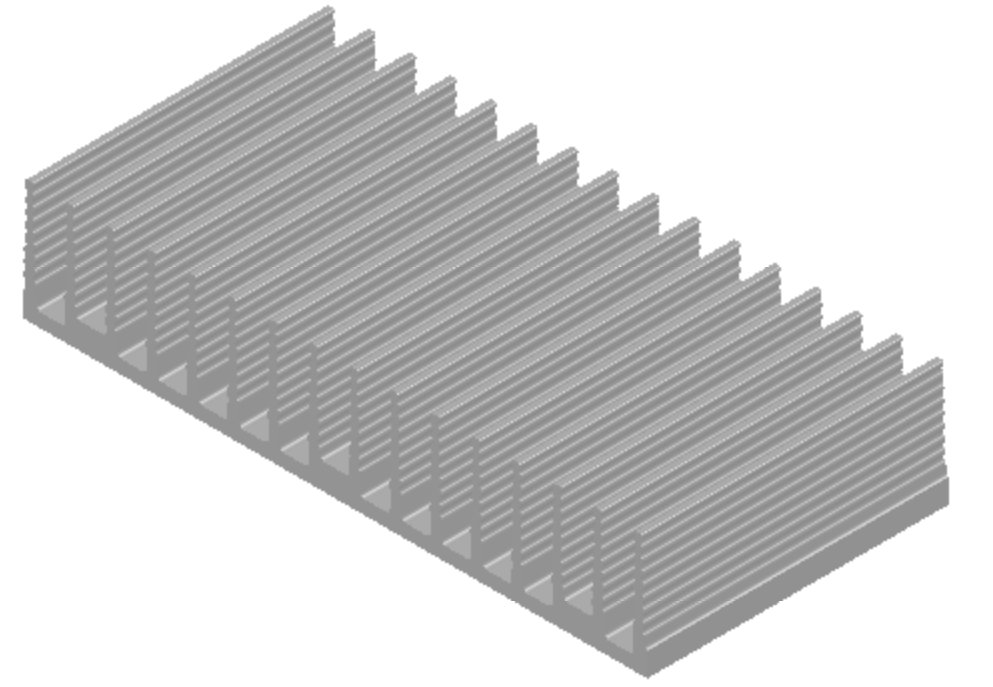
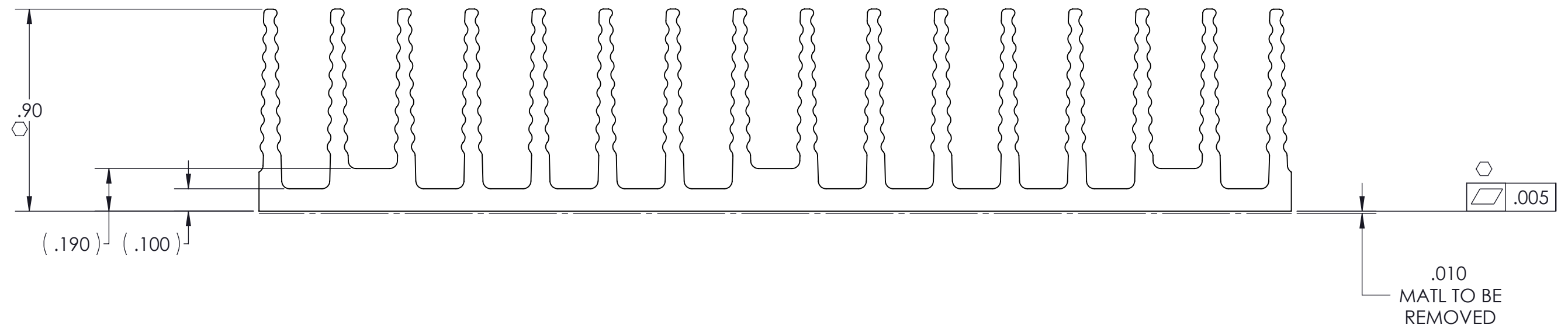
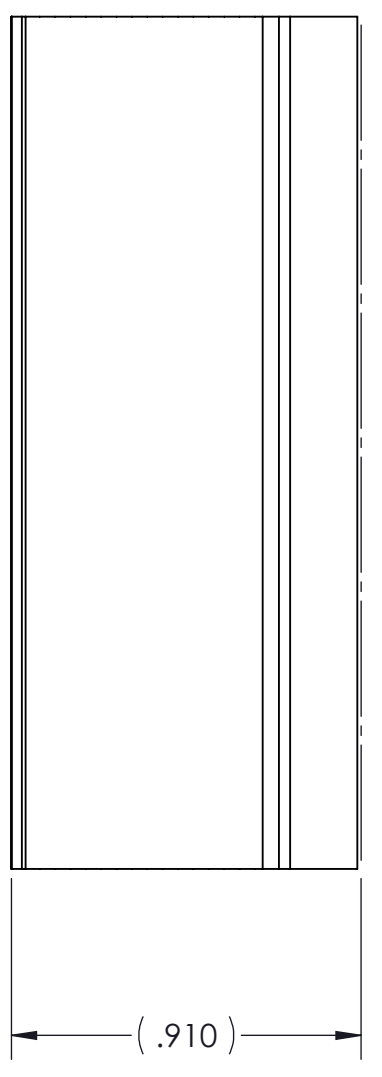
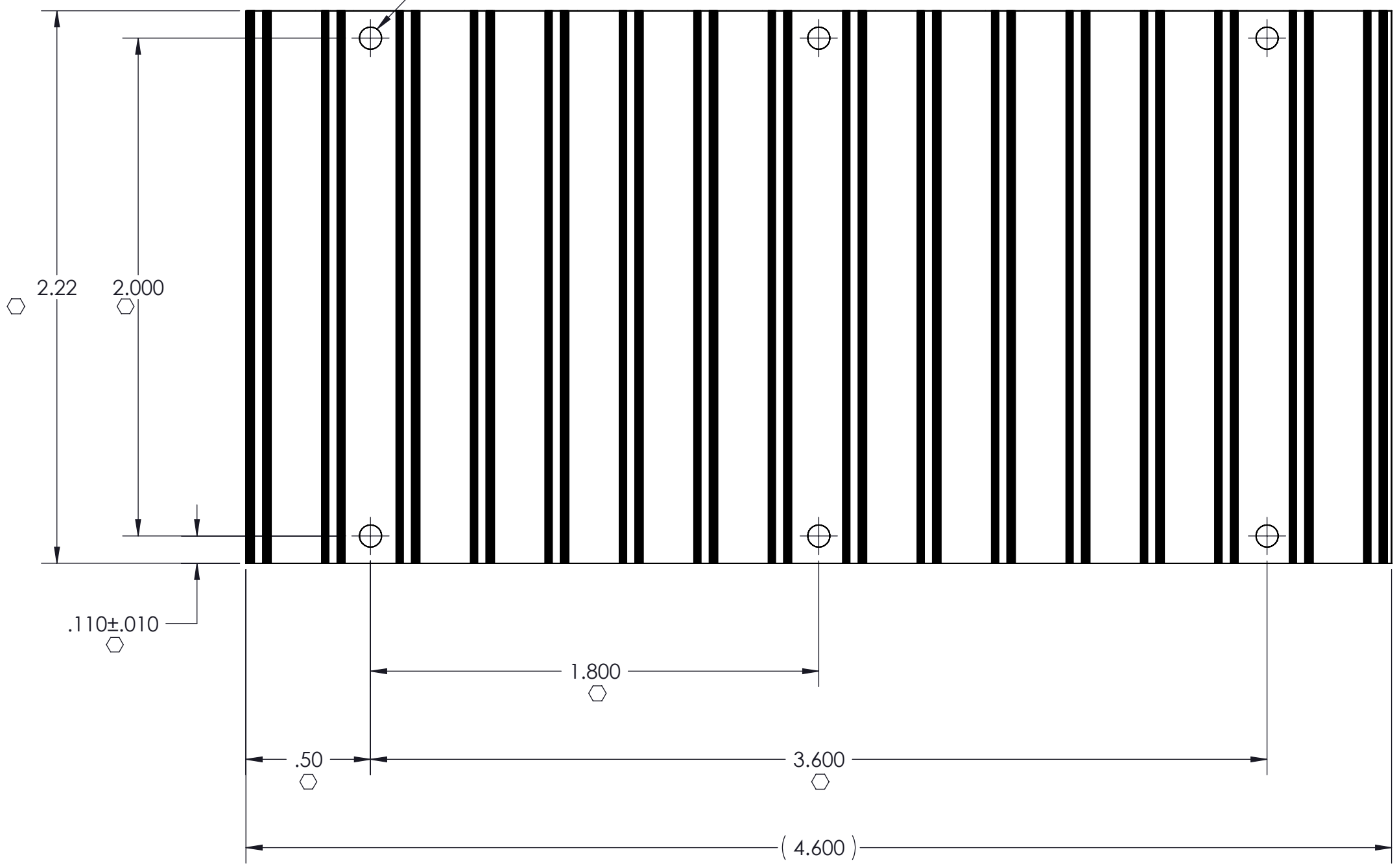

- NOTES:
1. MATERIAL: EXTRUSION SEE SHEET 2 OF 2.
 2. REMOVE ALL BURRS AND SHARP EDGES.
 3. CLEAR FINISH, RoHS COMPLIANT, CHROMIUM FREE PER CST-0001 LATEST REVISION.
 4. "◇" DENOTES CRITICAL CHARACTERISTICS FOR LOT INSPECTION.
 5. DIMENSIONS ARE INCHES ONLY.

DRAWN	DATE				
P. E. IENI	06/30/05				
MATERIAL	UNLESS OTHERWISE SPECIFIED DIMENSIONS ARE INCH [MM] TOLERANCES ARE: DECIMALS ANGLES X.XX [X.X] = ±0.01 [0.25] ±1° X.XXX [X.XX] = ±0.005 [0.127]	HS CFG "A", .90H, X-FLOW, LOW FLOW, THREADED			
SEE NOTES					
FINISH	THIRD ANGLE PROJECTION	SIZE	CAGE CODE	DWG NO	REV
SEE NOTES	 DO NOT SCALE DRAWING	C	67131	30196	3
		SCALE 2 : 1		SHEET 1 OF 2	

VICOR CONFIDENTIAL

THIS DOCUMENT AND THE DATA DISCLOSED HEREIN OR HEREWITH IS NOT TO BE REPRODUCED, USED OR DISCLOSED IN WHOLE OR IN PART TO ANYONE WITHOUT THE PERMISSION OF VICOR CORP.

REVISIONS

REV	DESCRIPTION	DATE	APPROVED
	SEE SHEET 1 OF 2		

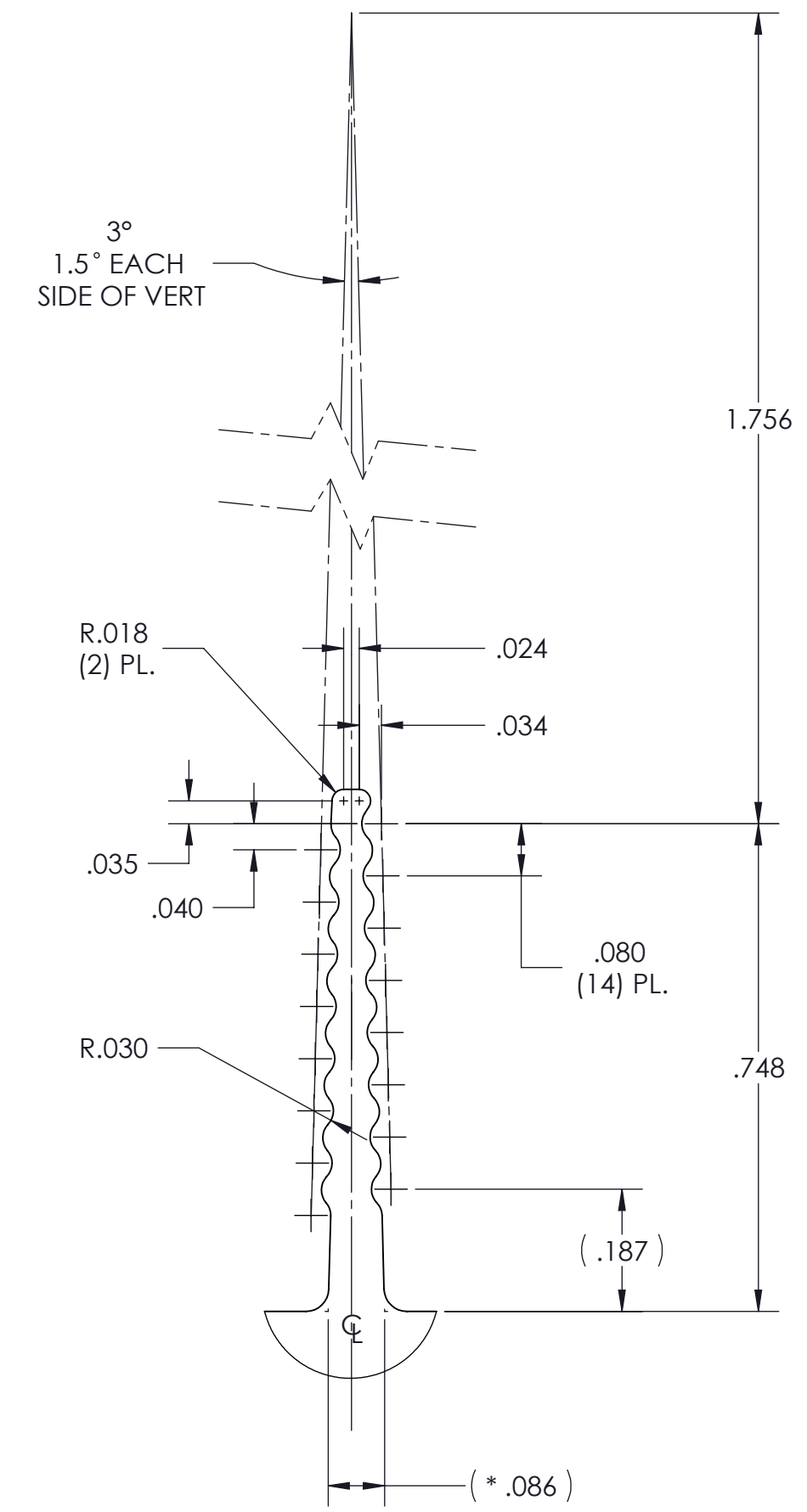
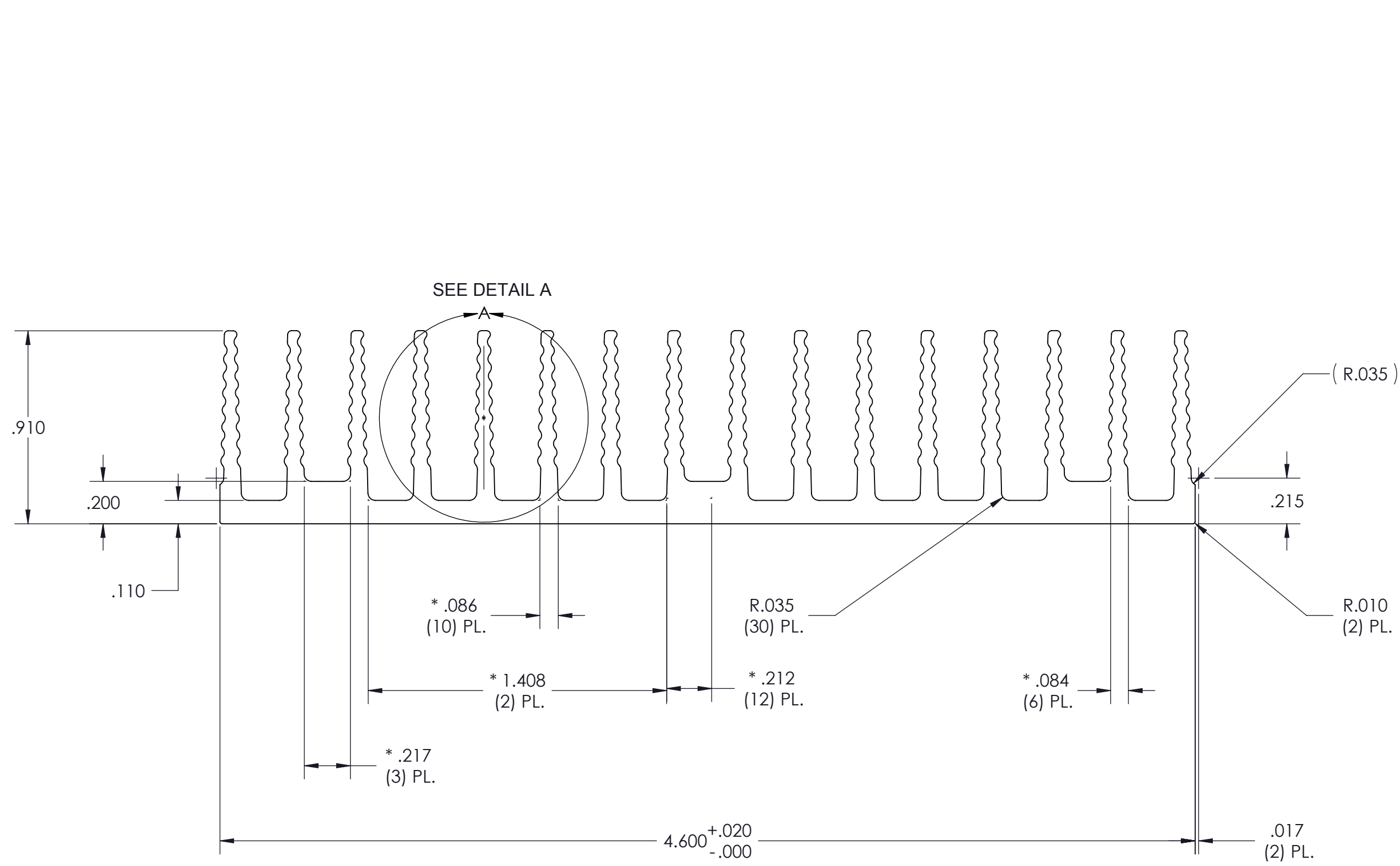

DETAIL A
SCALE 4 : 1

PROFILE COMMON FOR
30196
30723

- NOTES:
- MATL; ALUMINUM 6063-T5
 - * DENOTES DIMENSION TO THEORETICAL SHARP CORNER.
 - ALL DIMENSIONS ARE CRITICAL CHARACTERISTICS.
 - RoHS COMPLIANT PER CST-0001 LATEST REVISION.
 - WORKMANSHIP STANDARDS WS-0004, WS-0006, AND WS-0007 APPLY TO THIS PART.
 - DIMENSIONS ARE INCHES ONLY.

DRAWN	DATE				
JSARIPPELLA	9/11/09				
MATERIAL	UNLESS OTHERWISE SPECIFIED DIMENSIONS ARE INCH [MM]	HS CFG "A", .90H, X-FLOW, LOW FLOW, THREADED, EXTRUSION			
SEE NOTES	TOLERANCES ARE: DECIMALS ANGLES X.XX [X.X] = ±0.01 [0.25] ±1° X.XXX [X.XX] = ±0.005 [0.127]				
FINISH	THIRD ANGLE PROJECTION	SIZE	CAGE CODE	DWG NO	REV
SEE NOTES		C	67131	30196	3
		SCALE 2 : 1	SHEET 2 OF 2		