

VICOR CONFIDENTIAL
 THIS DOCUMENT AND THE DATA DISCLOSED HEREIN OR
 HEREWITH IS NOT TO BE REPRODUCED, USED OR
 DISCLOSED IN WHOLE OR IN PART TO ANYONE WITHOUT
 THE PERMISSION OF VICOR CORP.

REVISIONS			
REV	DESCRIPTION	DATE	APPROVED
1	RELEASE PER E110024a	AR 01/11/11	KUK

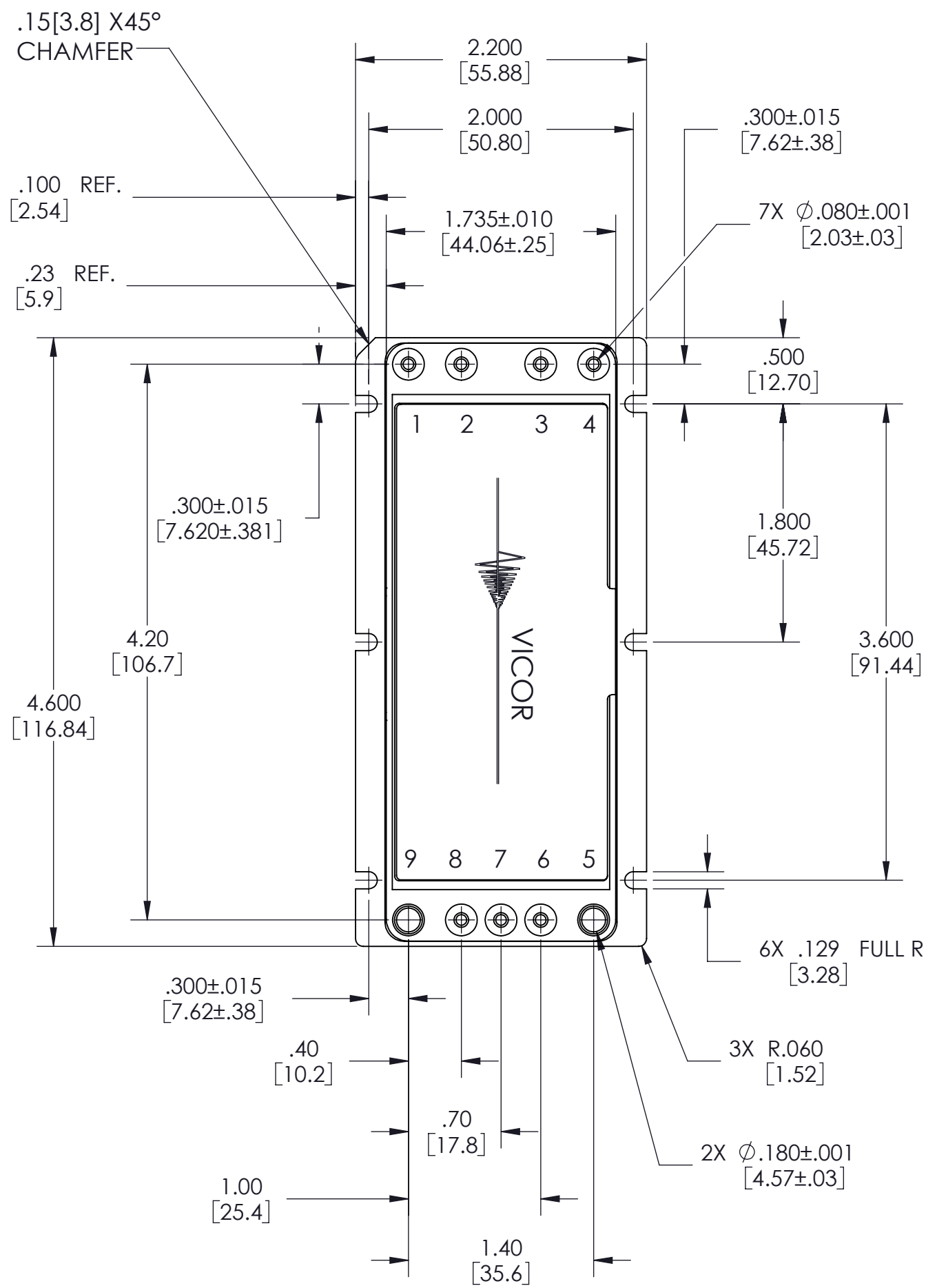

DIMENSION T
 SLOTTED.....0.12 [3.1]
 THRU & THREADED...0.20 [5.1]

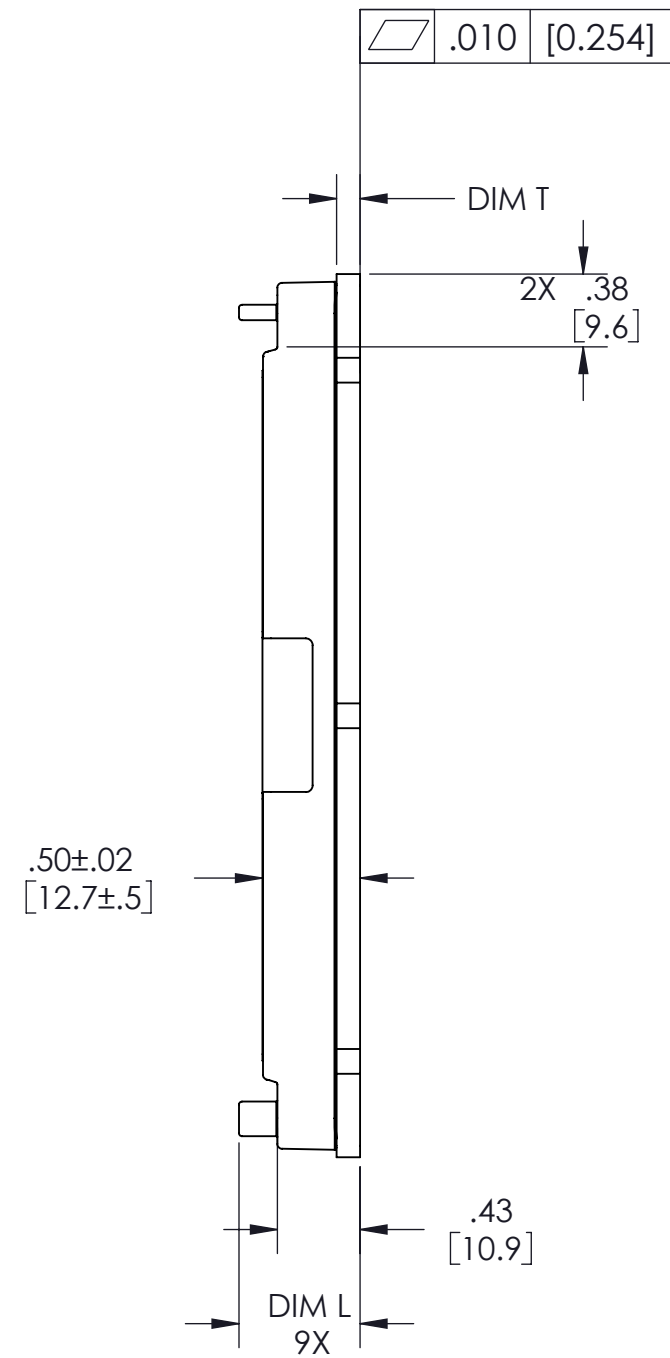

DIMENSION L
 PIN SHORT...0.55 ± .015 [14.0 ± .38]
 PIN LONG...0.63 ± .015 [16.0 ± .38]

SLOTTED BASEPLATE
 DIMENSIONS FOR ALL MODULE TYPES
 ARE SHOWN ABOVE; VERSIONS AT RIGHT
 SHOW DIMENSIONS THAT VARY.

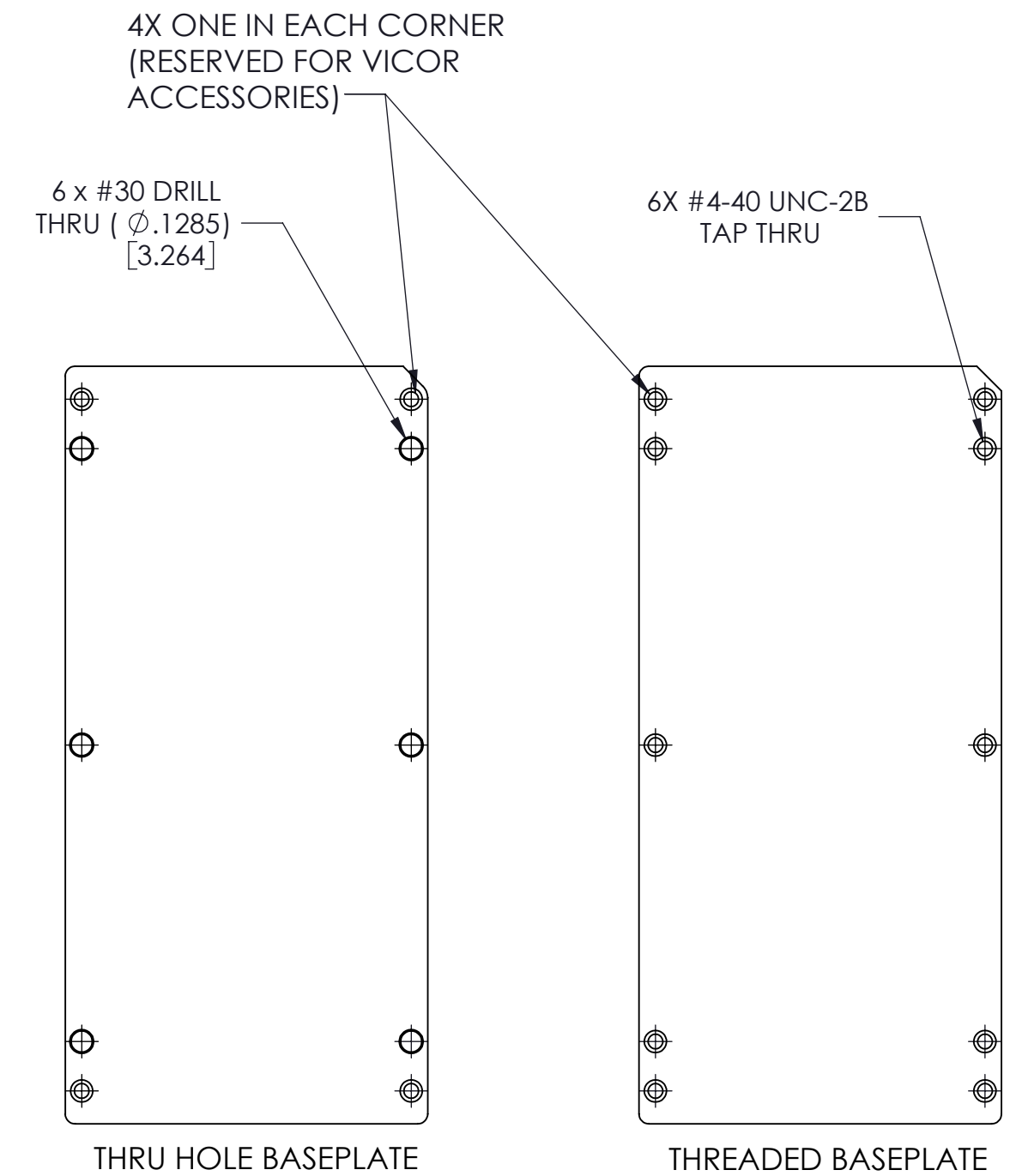

NOTES:
 1. MATERIAL:
 BASE: 6000 SERIES ALUMINUM
 PINS: ROHS PINS GOLD PLATE 30 MICRO INCH MIN;
 NON-ROHS PINS TIN/LEAD 90/10 BRIGHT.



DRAWN	DATE				
KRISHNA	12/20/2010				
MATERIAL	UNLESS OTHERWISE SPECIFIED DIMENSIONS ARE INCH [MM]		OUTLN DWG FAST TRACK MX PLASTIC		
FINISH	THIRD ANGLE PROJECTION				
		SIZE	CAGE CODE	DWG NO	REV
DO NOT SCALE DRAWING		C	67131	37205	1
SCALE 1 : 1			SHEET 1 OF 1		