

VICOR CONFIDENTIAL
 THIS DOCUMENT AND THE DATA DISCLOSED HEREIN OR
 HEREWITH IS NOT TO BE REPRODUCED, USED OR
 DISCLOSED IN ANY MANNER OR IN PART TO ANYONE WITHOUT
 THE PERMISSION OF VICOR CORP.

| REV. | DESCRIPTION | INTL | DATE | APVD |
|------|---------------------------|------|----------|------|
| 1 | RELEASED PER ECO E3160978 | AP | 10/3/16 | YZ |
| 2 | REVISED PER ECO180296a | US | 05/24/18 | AM |

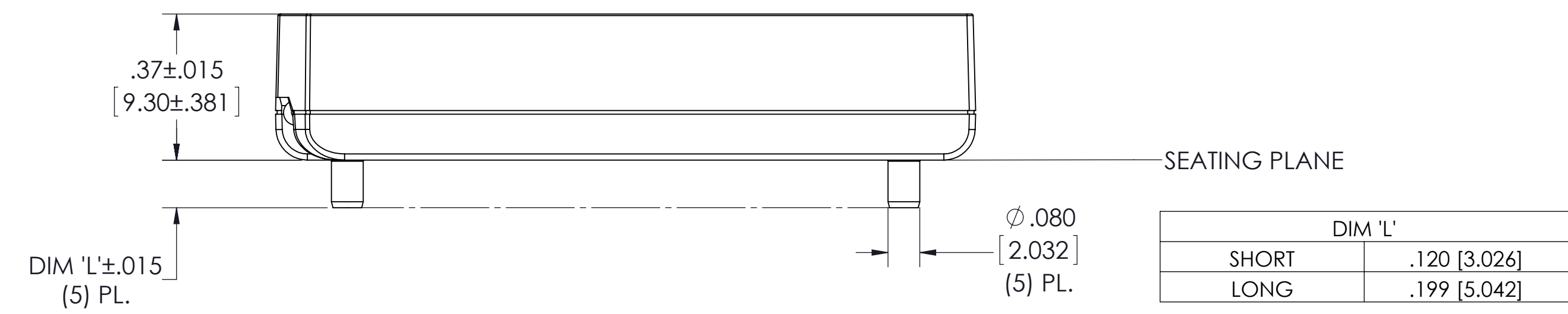

NOTE:
 1. RoHS COMPLIANT PER CST-0001 LATEST REVISION

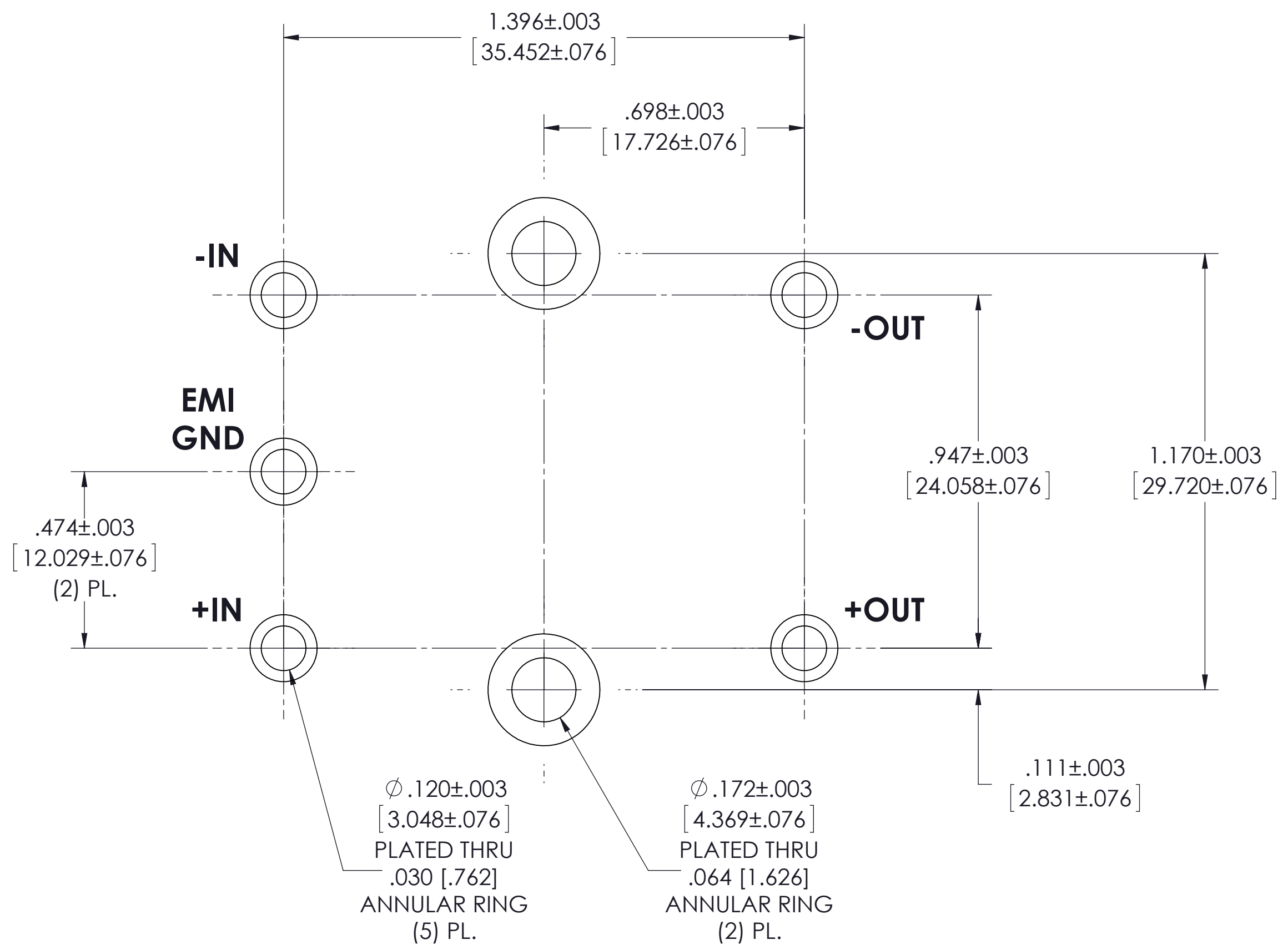
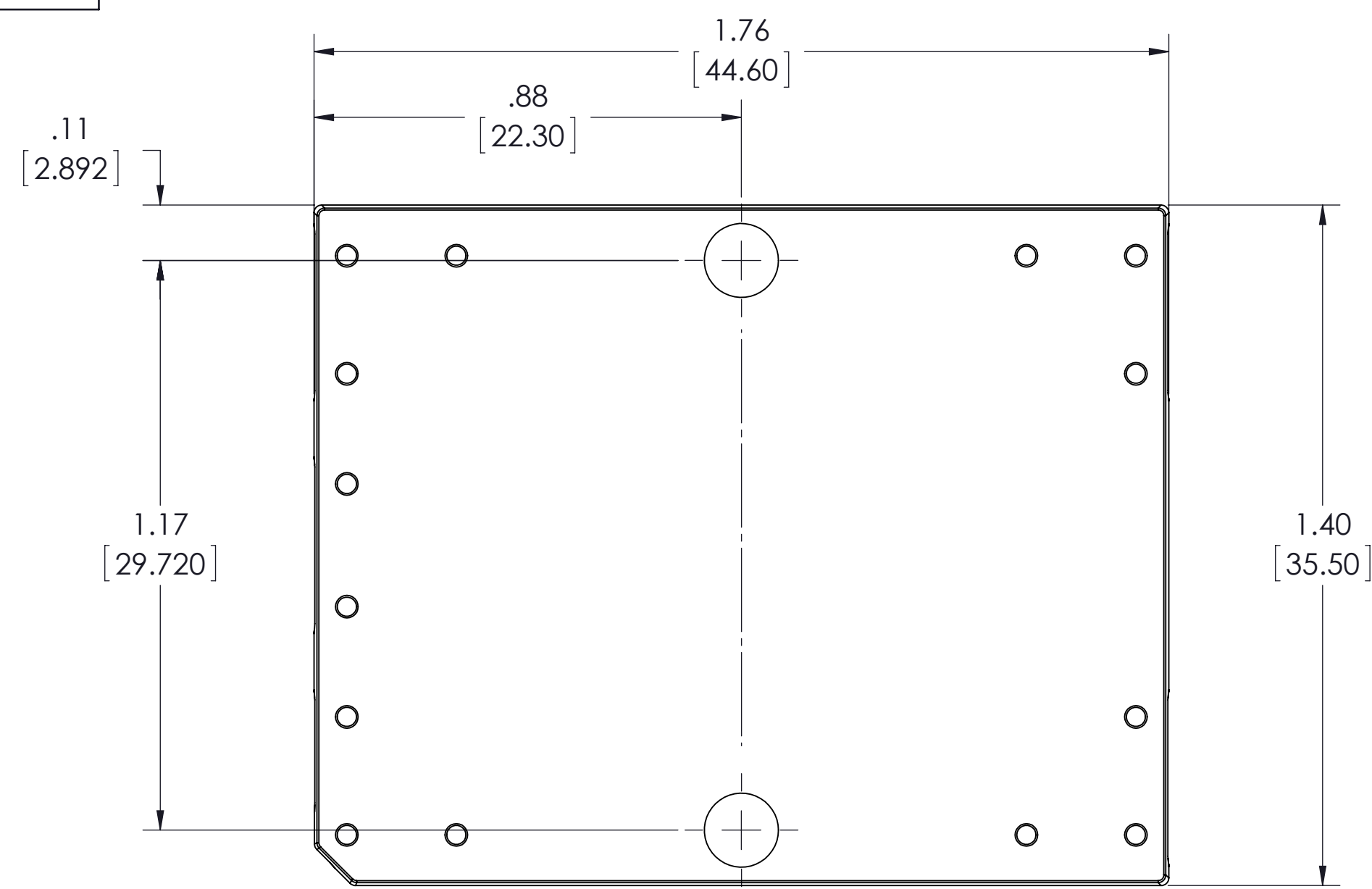
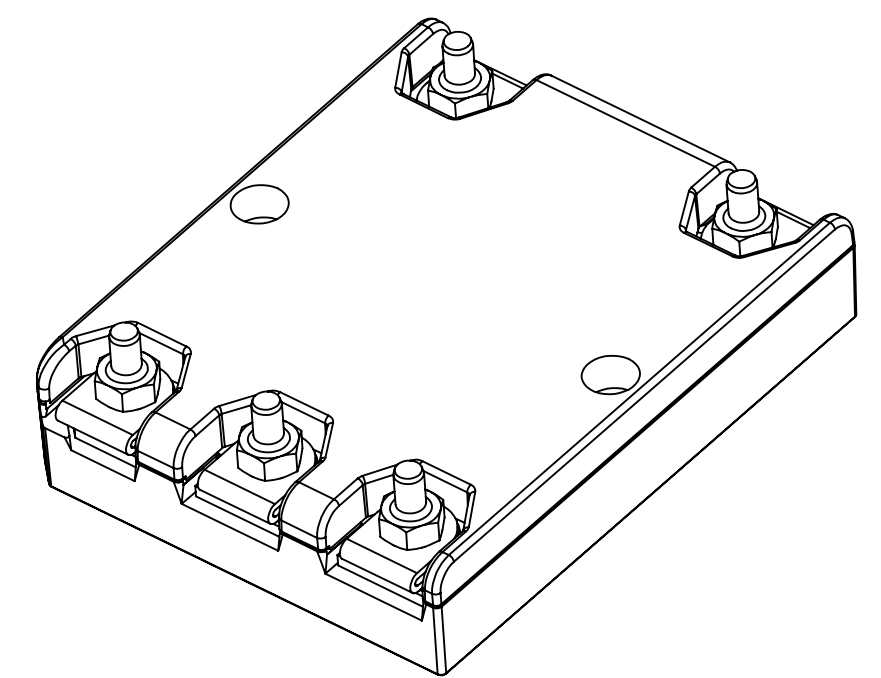
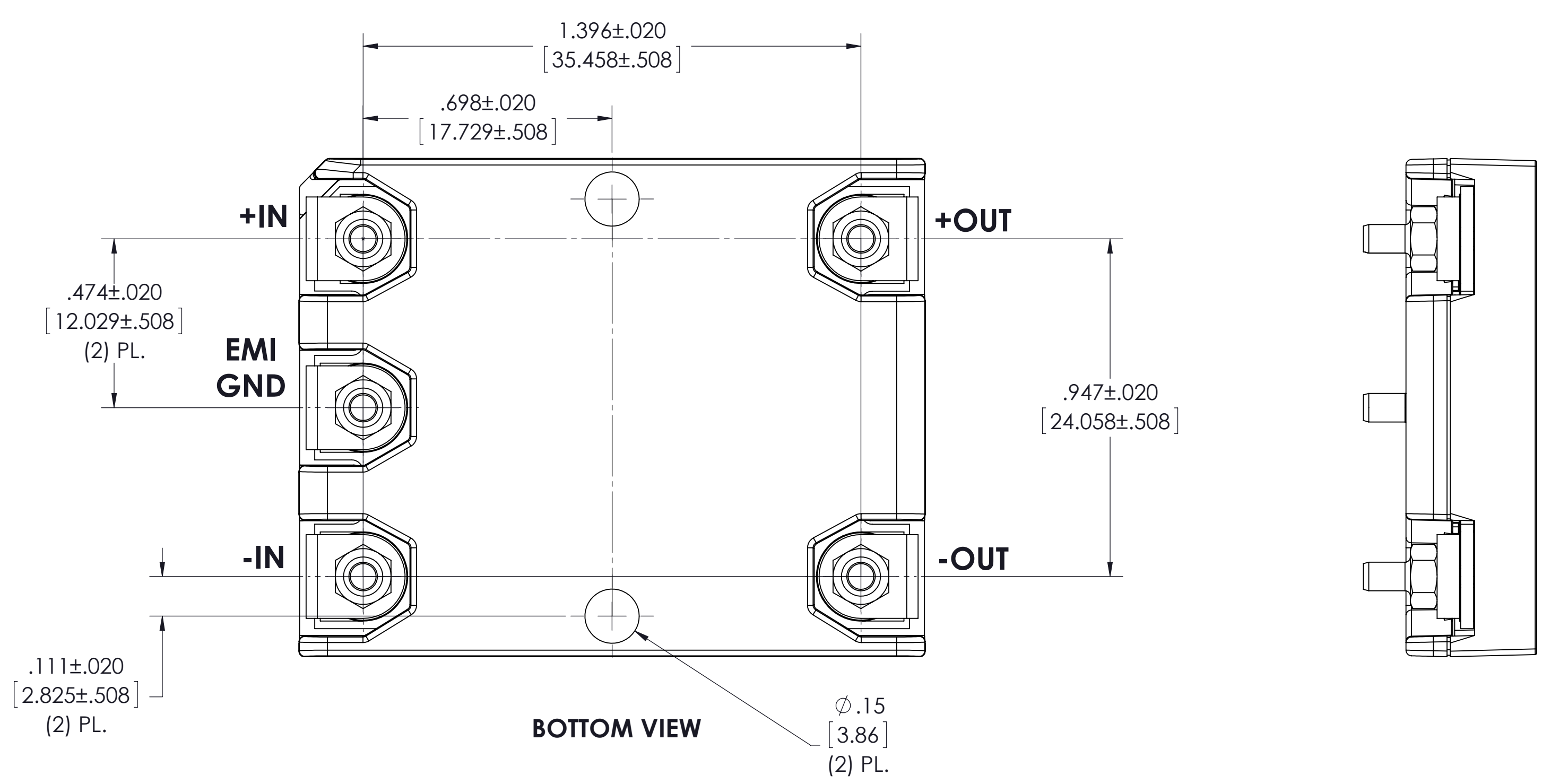

| | | | |
|---------------------------------------------------------------------------------------------|-------------------|----------------------------------------------------|---------------------------|
| DRAWN BY Matthew Biron | DATE 5/18/2016 | VICOR <small>swd</small> | |
| UNLESS OTHERWISE SPECIFIED DIMENSIONS ARE: INCH / (MM) | | PROD OUTL PCB MNT VIA DCM MIL HV FILTER | |
| TOLERANCES ARE: DECIMALS X.XX (X.XX) = ±0.01 (0.25) X.XXX (X.XXX) = ±0.005 (0.127) | ANGLES ° | SIZE D | CAGE CODE 67131 |
| THIRD ANGLE PROJECTION | SCALE 3.5:1 | DWG NO 44320 | REV 2 |
| DO NOT SCALE DRAWING | | SHEET 1 OF 1 | |