

VICOR CONFIDENTIAL
 THIS DOCUMENT AND THE DATA DISCLOSED HEREIN OR
 HEREIN IS NOT TO BE REPRODUCED, USED OR
 DISCLOSED IN WHOLE OR IN PART TO ANYONE WITHOUT
 THE PERMISSION OF VICOR CORP.

REV.	DESCRIPTION	INTL	DATE	APVD
1	Released per ECO E141368	ESD	1/19/15	RH
2	REVISED PER E190393	REJH	07/30/19	RLT

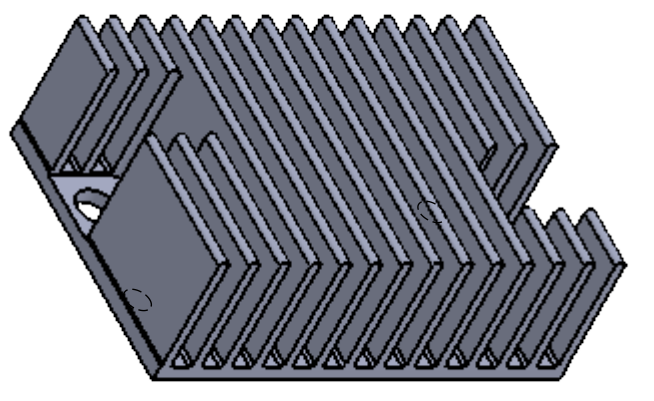
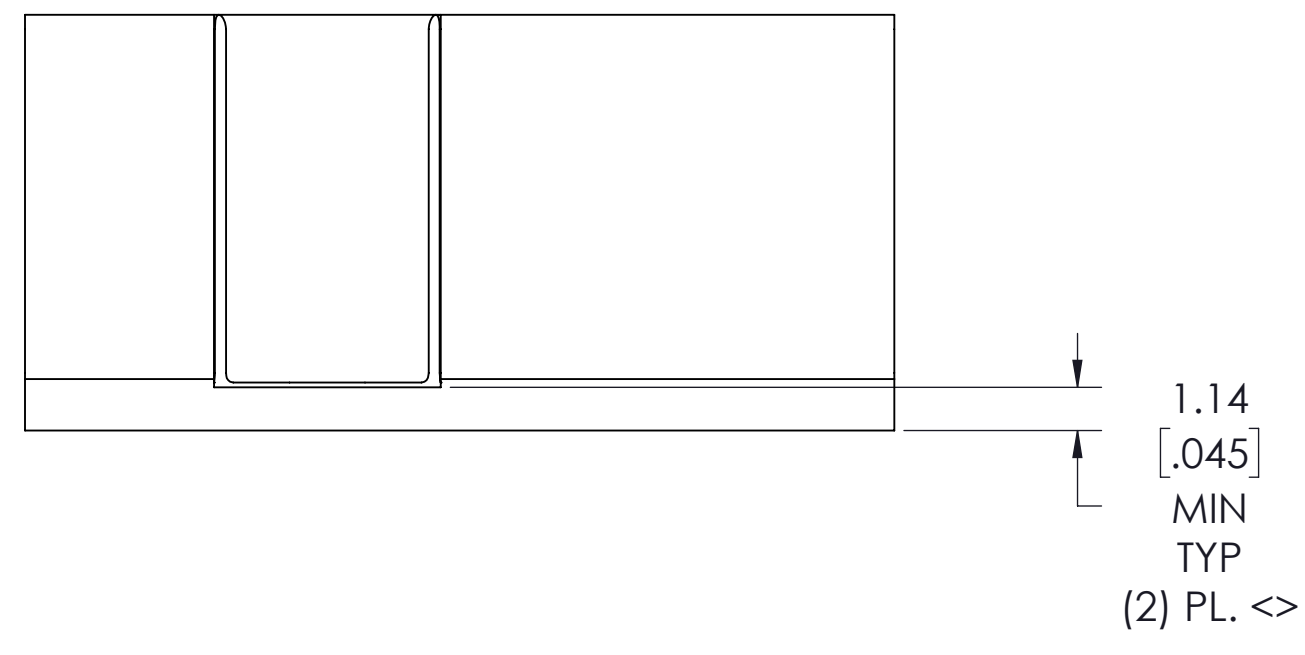
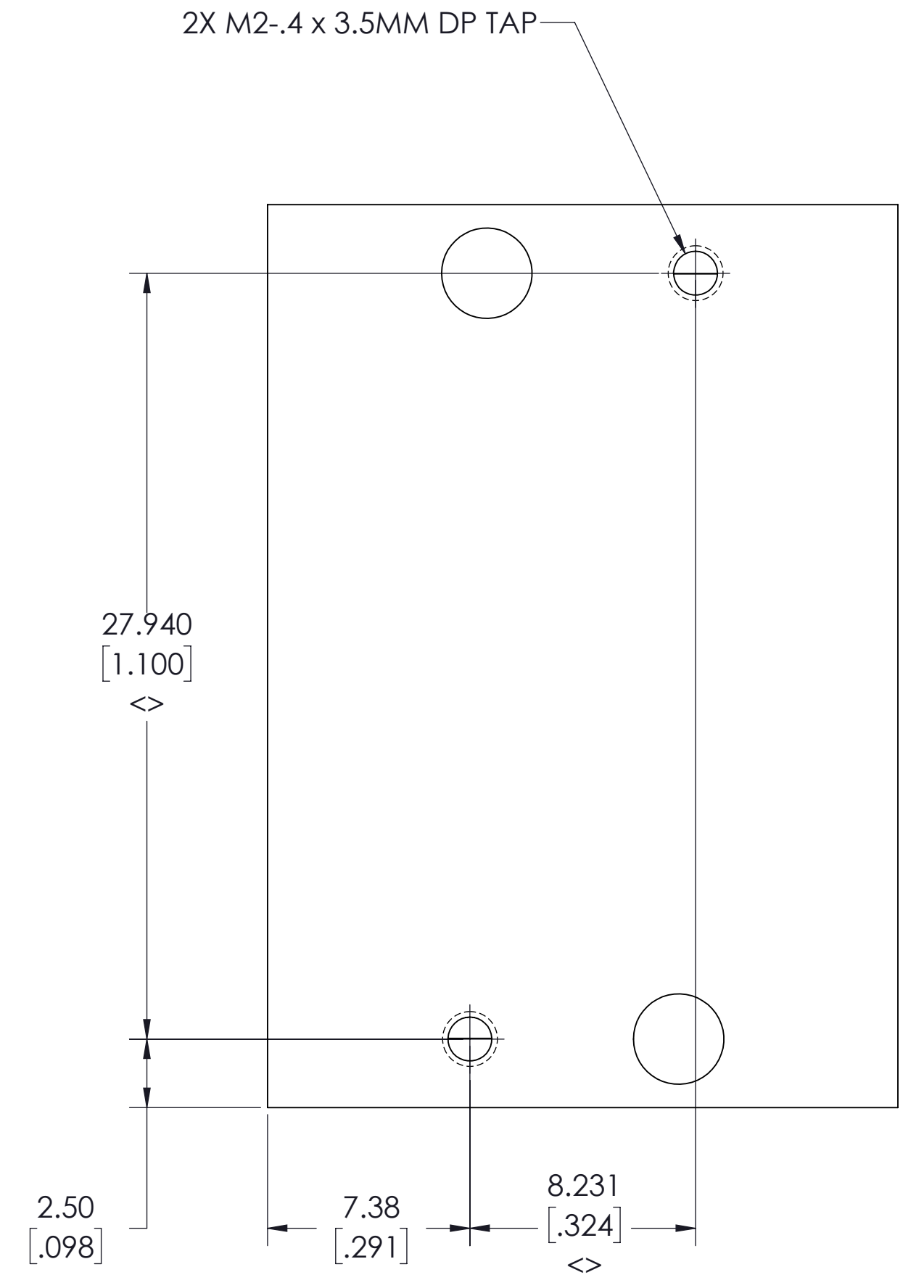
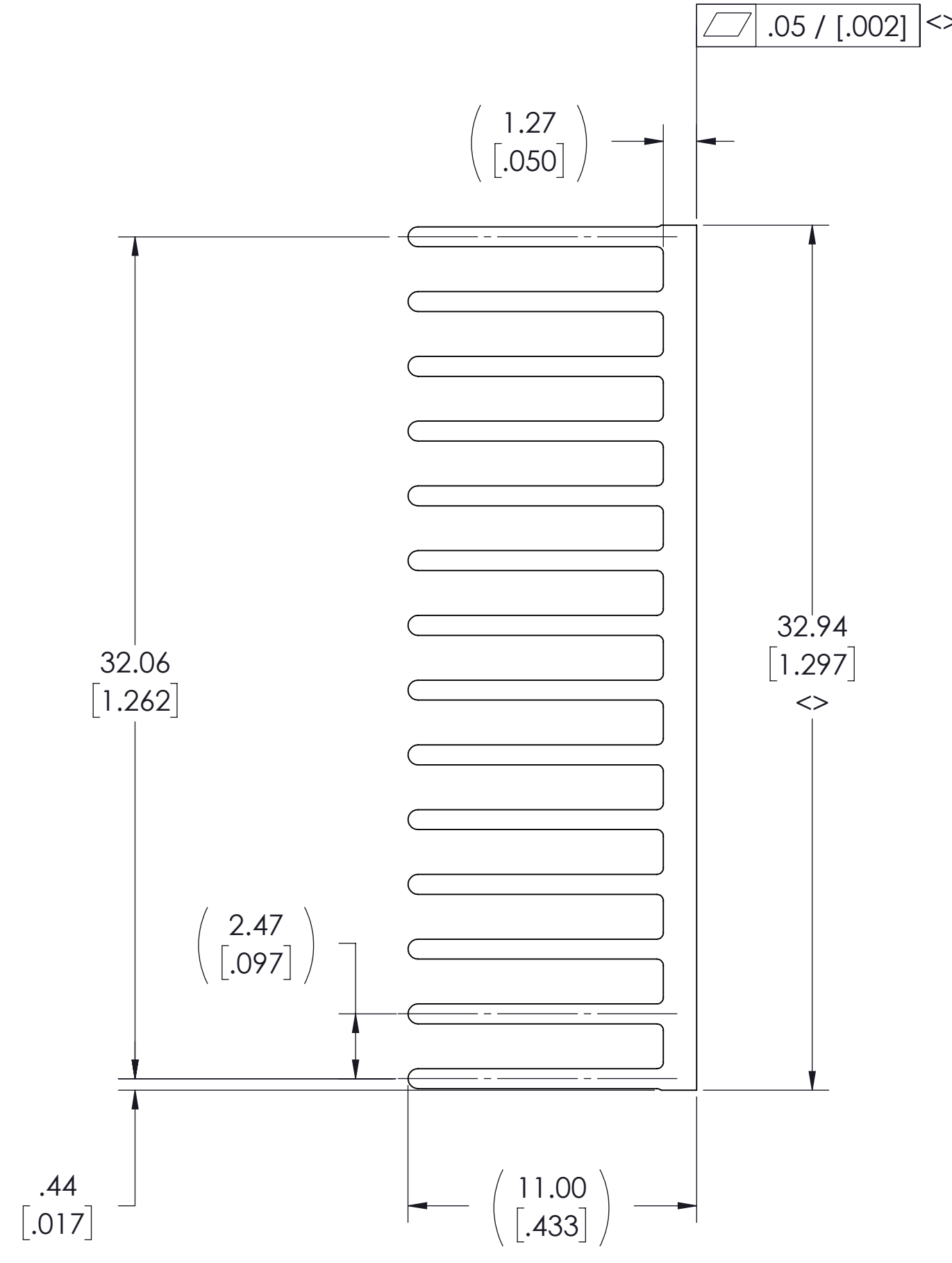
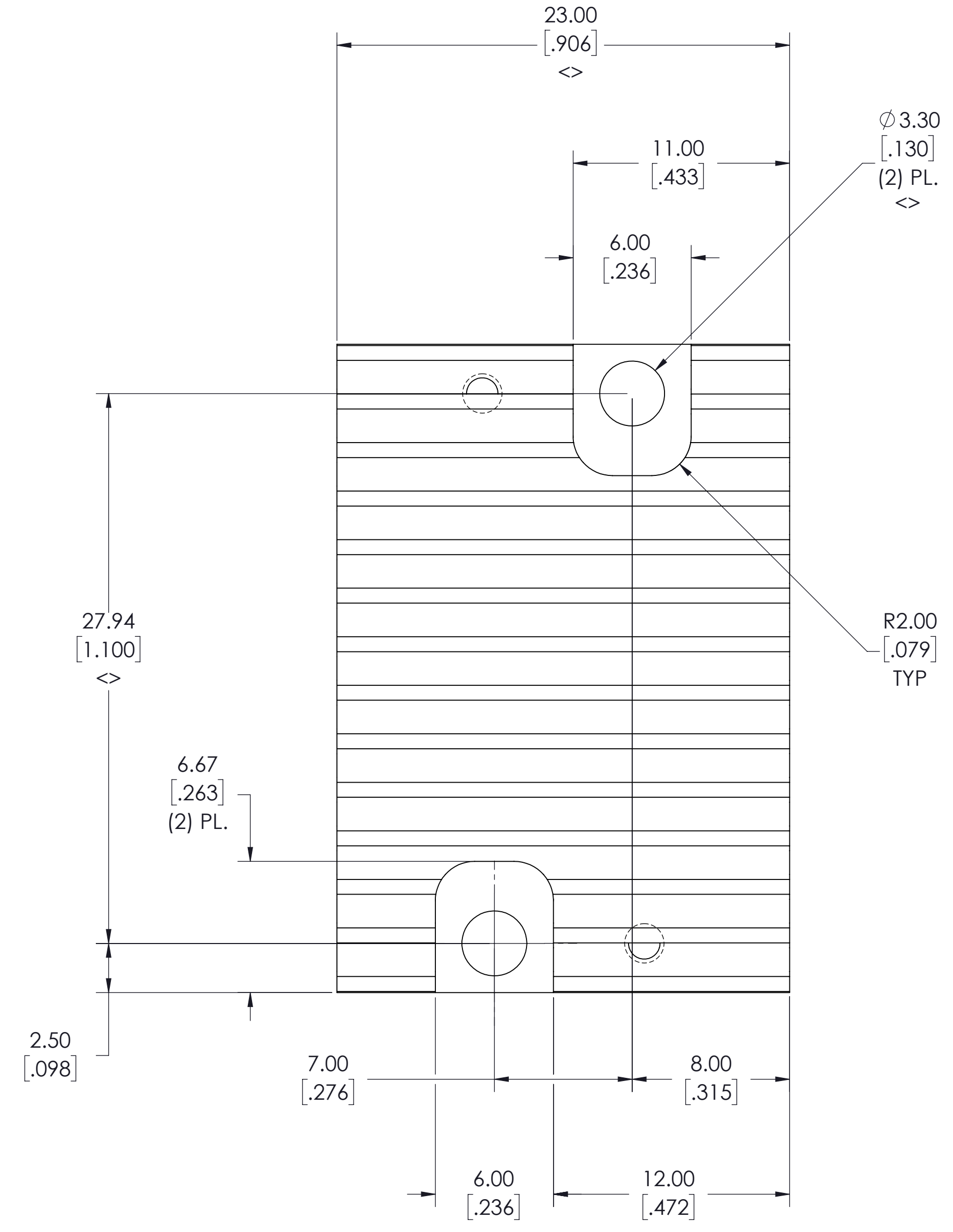

- NOTES:
- 1- MAKE FROM VICOR P/N 32618.
 - 2- FINISH: CLEAR FINISH, RoHS COMPLIANT PER CST-0001, LATEST REVISION PER
 A.) CHROMIUM FREE, OR
 B.) TRIVALENT CHROMIUM IN ACCORDANCE WITH MIL-DTL-5541, TYPE II, CLASS 1A OR 3. SEE CST-0003 FOR TYPES OF AVAILABLE FINISHES.
 - 3- REMOVE ALL BURRS AND SHARP EDGES.
 - 4- <> DENOTES CRITICAL CHARACTERISTIC FOR LOT INSPECTION.
 - 5- ROHS COMPLIANT, LEAD FREE PER CST-0001 LATEST REVISION.

DRAWN BY Chris Stewart	DATE 4/4/2013	VICOR <small>swd</small>	
UNLESS OTHERWISE SPECIFIED DIMENSIONS ARE: INCH / (MM)		HEATSINK, PUSH PIN, LF, 2322, 11MM	
TOLERANCES ARE: DECIMALS: .XX (X.X) = +0.01 (0.25) X.XXX (X.XXX) = ±0.005 (0.127)		SIZE D 67131	DWG NO 39821
THIRD ANGLE PROJECTION DO NOT SCALE DRAWING		SCALE 5:1	REV 2 SHEET 1 OF 1