

**VICOR CONFIDENTIAL**  
 THIS DOCUMENT AND THE DATA DISCLOSED  
 HEREIN OR HEREWITH IS NOT TO BE REPRODUCED,  
 USED, OR DISCLOSED IN WHOLE OR IN PART  
 TO ANYONE WITHOUT PERMISSION OF VICOR CORP.

REV.	DESCRIPTION	DATE	APVD
1	RELEASED PER E100198	JS 02/26/10	RE.H

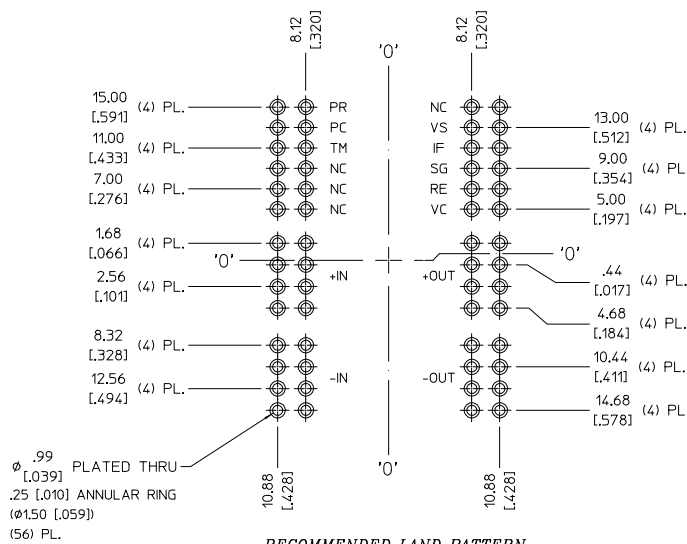
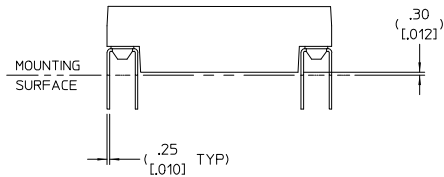
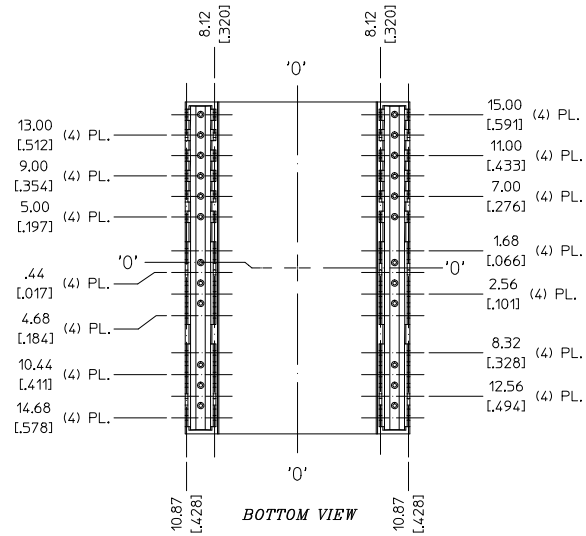
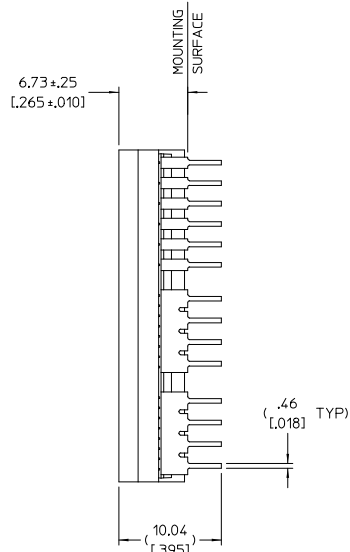
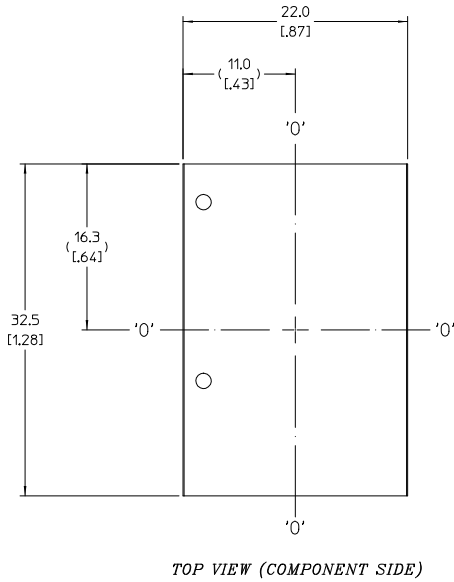

NOTE:  
 1. RoHS COMPLIANT PER CST-0001 LATEST REVISION.

**RECOMMENDED LAND PATTERN  
 (COMPONENT SIDE SHOWN)**

DRAWN BY: J.S. LARSEN	DATE: 12/02/09		
<small>UNLESS OTHERWISE SPECIFIED DIMENSIONS ARE IN INCH TOLERANCES ARE: DECIMALS .005 FRACTIONS .0001 ANGLES .01</small>			
<small>THIRD ANGLE PROJECTION</small>		<b>PRODUCT OUTLINE DWG.</b> <b>PRM2(RS) W/TH-LEADS PKG3</b>	
SIZE: D	CAGE CODE: 67131	DWG NO: 36132	REV: 1
SCALE: 4:1	SHEET 1 OF 1		