

PROPRIETARY DATA:
This document and information contained
may not be reproduced, used or disclosed
without prior written permission of WESTCOR
a division of VICOR Corporation.

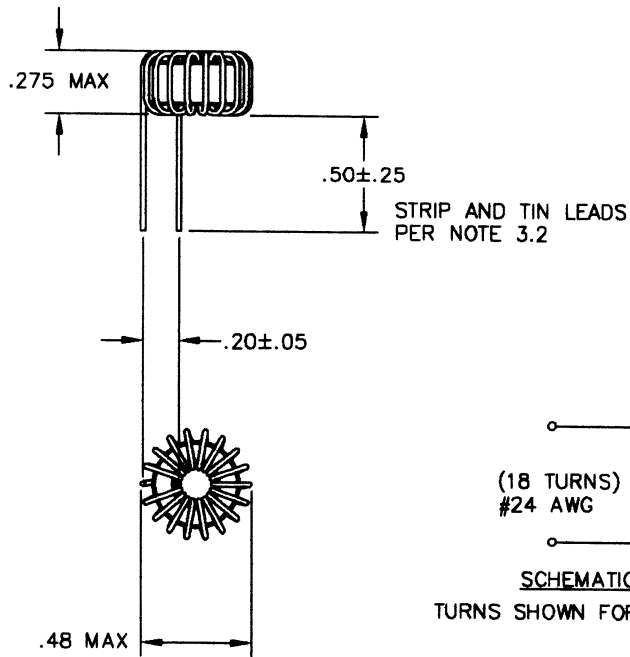

REVISIONS				
ECO	REV	DESCRIPTION	DATE	APPROVED
367	A	PRODUCTION RELEASE	2/3/95	RBD
421	B	NOTE 2.1 WAS: 1.1MH, IS: 1.3MH	7/18/95	RBD
549	C	CHG: NOTE 2.1, WAS: 1.3mH, IS: 0.9-2 AT 1KHz	6/5/96	RBD
--	C1	CHG NOTE 2.1 TO: 0.8 - 1.3 MH AT 1KHZ	03/08/04	RBD
1462	D	ADDED ROHS SPEC NOTE	06/21/05	LJK
--	D1	CHG NOTE 2.1 FROM: 1.3 TO: 1.4mH	07/22/05	DAF
1578	E	CHG HEIGHT DIM FR: .25 TO .275 (MAX)	06/08/06	DAF
--	E1	CHG NOTE 2 TO MIN 0.8mH	07/26/06	DAF
1710	F	ADD TEST VOLTAGE TO NOTE 2.1	10/02/06	DAF
--	F1	CHG NOTE 2.1 FR: 1 VOLT TO: 500MV	01/18/07	DAF
--	F2	ADD CORE TO 1.1 & 2.1 CHG 500 TO 100MV	01/18/07	DAF

NOTES: UNLESS OTHERWISE SPECIFIED,

1. MATERIALS: UL RECOGNIZED 94V-2 FLAMMABILITY RATING CLASS B (130°C) REQUIRED.
 - 1.1 CORE: TOROID - .375 X .187 X .188 (u = 5000)
MAGNETICS: ZJ-41005-TC
FAIR-RITE: 5975002501 (COATED)
STEWART: 35T0375-30P
ACME: T9.53 X 4.75 X 4.80 A05
 - 1.2 WIRE: U.L. RECOGNIZED 130°C RATING MAGNET WIRE.
APPROVED MFR: ESSEX; OTHER MFR HAS TO BE ROHS COMPLIANT CERTIFIED BEFORE USE
2. SPECIFICATIONS:
 - 2.1 L = MIN 0.8-mH @ 100 mV 1 KHz TEST FREQUENCY
 - 2.2 DCR = 35 mOHMS MAX
3. CONSTRUCTION:
 - 3.1 WIND
 - 3.2 TIN LEADS CLOSE TO CORE AS SHOWN
 - 3.3 LABEL BULK PACKAGE WITH DRAWING NUMBER AND REVISION, VENDOR IDENTIFICATION, AND DATE OF MANUFACTURE.

NOTE: CERTIFICATION OF MATERIAL COMPLIANCE REQUIRED.
COMPLETED ASSEMBLY MUST BE (RoHS) COMPLIANT
PER VICOR SPEC CST-0001.

		UNLESS OTHERWISE SPECIFIED DIMENSIONS ARE IN INCHES TOLERANCES ARE:	CONTRACT NO.		WESTCOR a division of VICOR Corp.	
		FRACTIONS DECIMALS ANGLES ± 1/32 .XX ± .01 ± 1/2° .XXX ± .006	APPROVALS DATE			
		MATERIAL SEE NOTE 1	DRAWN S. KEITH	10/13/94	INDUCTOR 1 MH TOROID	
		FINISH NONE	CHECKED HONDO	01/28/99		
NEXT ASSY	USED ON		APPROVED R. DRABING	10/13/94	SIZE B	CAGE CODE
APPLICATION		DO NOT SCALE DRAWING	DESIGNED R. DRABING	10/13/94	DWG NO. 36-00030	REV F2
			SCALE NTS	FILENAME: 36-00030.DWG	SHEET 1 OF 1	