

REV.	DESCRIPTION	INTL	DATE	APVD
1	Released per ECO E141368	ESD	01/19/2015	RH

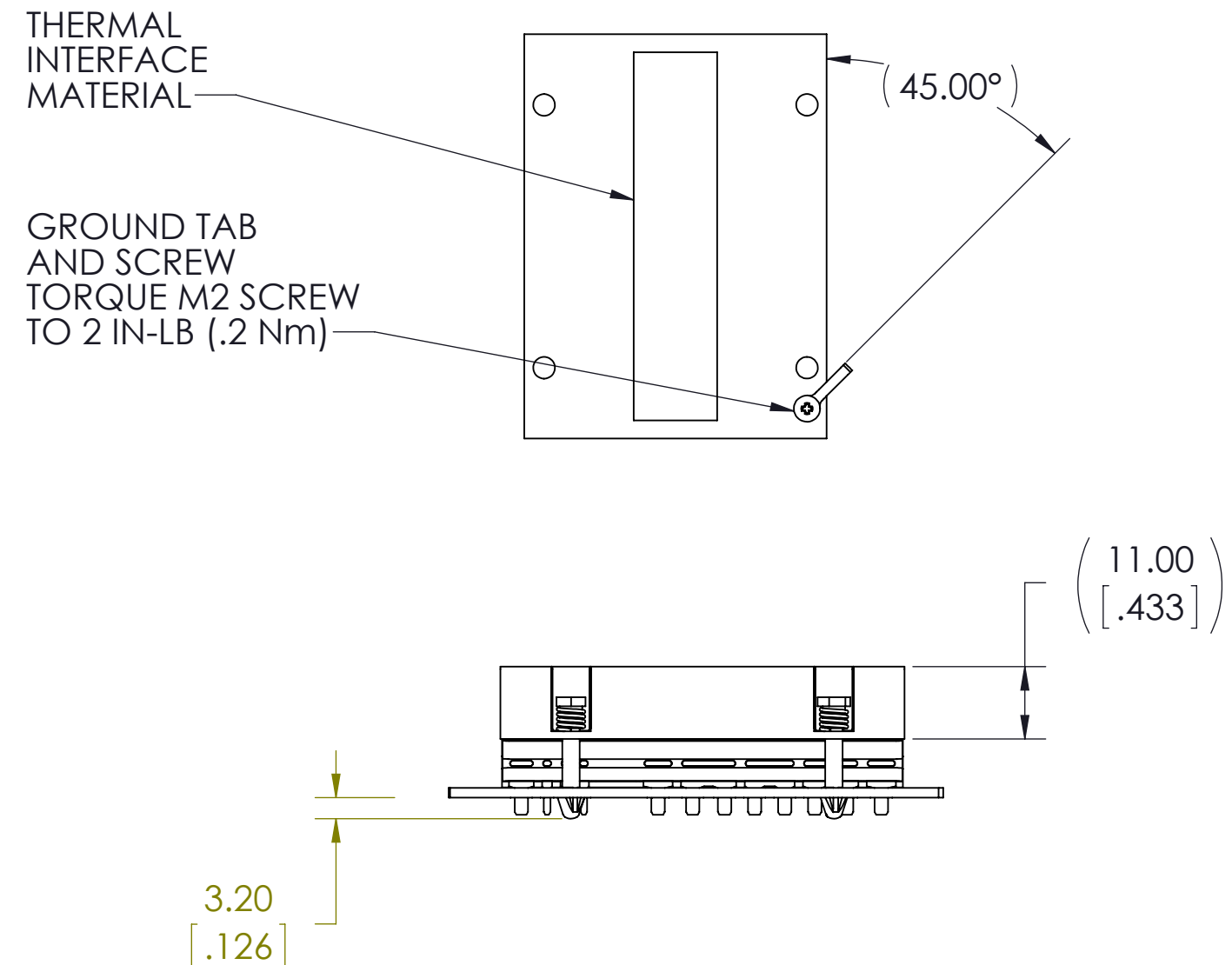
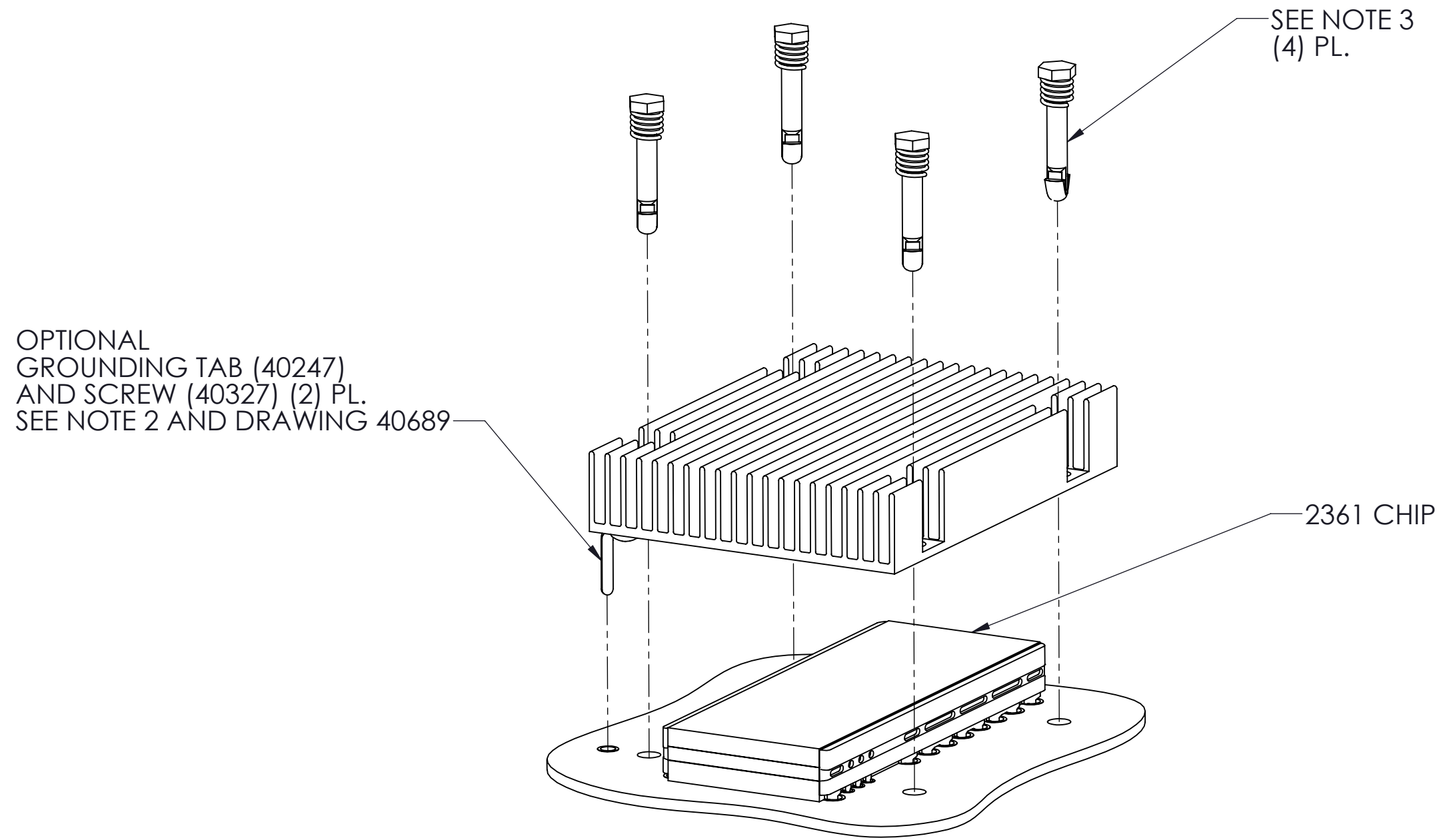

ISO ASSY REF ONLY

NOTES:

- FOR PCB LAYOUT SEE VICOR APPLICATION DRAWING 40689.
- THE SOLDERING METHOD USED FOR CHIPS (AND OPTIONAL HEATSINK GROUNDING) IS IMPORTANT WHEN SELECTING A THERMAL INTERFACE MATERIAL (TIM). THE PHASE-CHANGE TIM SHOWN IN THESE ILLUSTRATIONS MAY BE DAMAGED BY TEMPERATURES OVER 125C, SO TWO ASSEMBLY PROCEDURES ARE DESCRIBED BELOW:
 (A) FOR HAND-SOLDERING ONLY,
 (B) FOR WAVE-SOLDERING AND/OR HAND-SOLDERING.

 (A) PLACE CHIP AND TOP-SIDE HEATSINK (WITH PRE-ATTACHED TIM AND GROUNDING TAB) ON PCB. WHILE SUPPORTING PCB, INSERT PLASTIC PUSH-PINS THROUGH HEATSINK AND PCB. (SELECT PROPER PUSH-PIN LENGTH FROM TABLE ON THIS DRAWING.) HAND-SOLDER CHIP AND GROUNDING PIN.

 (B) WAVE SOLDERING TEMPERATURES ARE UNSUITABLE FOR PLASTIC PUSH-PINS AND PHASE-CHANGE TIM, SO VICOR TIM 40325 (PARKER CHOMERICS GEL8010) IS RECOMMENDED. APPLY A UNIFORM .003" (.076MM) LAYER OF TIM 40325 TO THE TOP SURFACE OF THE CHIP, OR TO THE BOTTOM SURFACE OF THE HEATSINK. PLACE CHIP ON PCB AND TOP-SIDE HEATSINK ON CHIP. WITH A CUSTOM FIXTURE APPLY APPROX. 10 LBS LOAD TO THE TOP-SIDE HEATSINK AND THEN WAVE-SOLDER ALL PINS. REMOVE FIXTURE AND, WHILE SUPPORTING PCB, INSERT PLASTIC PUSH-PINS THROUGH HEATSINK AND PCB. (SELECT PROPER PUSH-PIN LENGTH FROM TABLE ON THIS DRAWING.)
- CARE SHOULD BE TAKEN TO AVOID FULLY COMPRESSING THE PUSH-PIN SPRING DURING INSTALLATION AS THIS WOULD EXPOSE THE CHIP TO FORCES GREATER THAN THE RECOMMENDED LIMIT OF 3.1 LBF (13.8 N) PER PUSH-PIN.
- RoHS COMPLIANT PER CST-0001 LATEST REVISION.

PUSH-PIN FOR CHIP HEATSINK CHART

PUSH-PINS W/ SPRINGS (100/BAG)	COLOR	PCB THK NOMINAL RANGE	PCB THK MINIMUM	PCB THK MAXIMUM
32434	WHITE	1.143 MM TO 1.422 MM [.045"] TO [.056"]	1.016 MM [.040"]	1.575 MM [.062"]
32435	BLACK	1.448 MM TO 2.311 MM [.057"] TO [.091"]	1.295 MM [.051"]	2.565 MM [.101"]
32436	BLUE	2.337 MM TO 3.023 MM [.092"] TO [.119"]	2.083 MM [.082"]	3.353 MM [.132"]
32437	GRAY	3.048 MM TO 3.607 MM [.120"] TO [.142"]	2.743 MM [.108"]	3.988 MM [.157"]

DRAWN BY Robert Wasik	DATE 02/24/2014	VICOR SWD	
UNLESS OTHERWISE SPECIFIED DIMENSIONS ARE MM / (INCH)		APP DWG ChiP PUSHPIN HS TOP 2361	
TOLERANCES ARE: DECIMALS ANGLES X.XX [X.X] = ±0.25 [0.01] ±1° X.XXX [X.XXX] = ±0.127 [0.005]			
THIRD ANGLE PROJECTION 	SIZE C	CAGE CODE 67131	DWG NO 40703
DO NOT SCALE DRAWING	SCALE 1:1	REV 1	SHEET 1 OF 1